

More compact, lighter, cleaner and more efficient

For total elimination of air from heating and cooling installations.

Air separators increase comfort and improve the yield. Air separators also offer benefits in the event of application in old systems or when an open system is converted to a closed system.

- Increases comfort and yield.
- The removal of air from the system water extends the service life of pumps, control equipment and other system accessories.

The Flamcovent Smart air separators remove even the smallest microbubbles from the system water. They are virtually maintenance-free and the flow resistance is negligibly low.





Advantages

- 60% better performance compared to conventional separators.
- Flow velocity up to 3 m/s.
- Can be used with all kinds of pipework.
- Compact dimensions, light weight.
- Extremely low flow resistance and low loss of energy.
- Consistent performance throughout its service life.

Technical Specifications

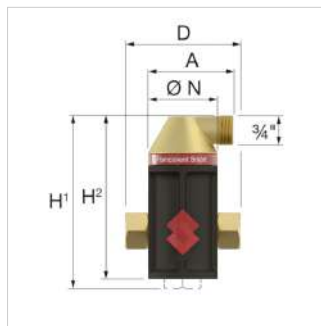
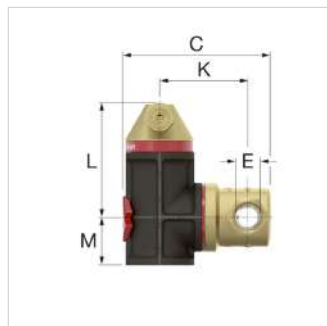
- Materials: brass and high-quality plastic.
- Minimum/Maximum operating temperature: -10 °C / 120 °C.
- Minimum/Maximum system pressure: 0,2 / 10 bar.
- Minimum/Maximum operating pressure: 0,2 / 6 bar.
- Suitable for addition of glycol-based anti-freeze up to 50%.



Type	Connection (E)	Dimensions									Weight [kg]		Order Code
		A [mm]	C [mm]	D [mm]	K [mm]	L [mm]	M [mm]	H/H1 [mm]	H2 [mm]	Ø N [mm]			
Flamcovent Smart 22	22 mm	74	134	120	78	101	37	161	138	60	0.95	1	30002
Flamcovent Smart 3/4	G 3/4" F	74	132	100	78	101	37	151	138	60	0.90	1	30001
Flamcovent Smart 1	G 1" F	82	155	106	91	139	45	192	184	75	1.12	1	30003
Flamcovent Smart 1 1/4	G 1 1/4" F	82	165	110	96	139	45	194	184	75	1.27	1	30004
Flamcovent Smart 1 1/2	G 1 1/2" F	94	193	129	109	173	54	238	227	92	1.73	1	30005
Flamcovent Smart 2	G 2" F	94	206	140	117	173	54	243	227	92	2.16	1	30006

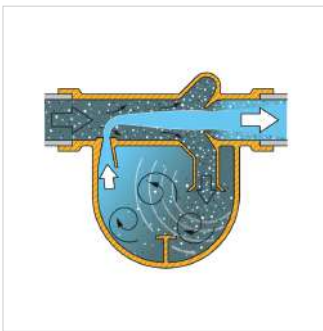

Selection table for Flamcovent & Clean Smart series

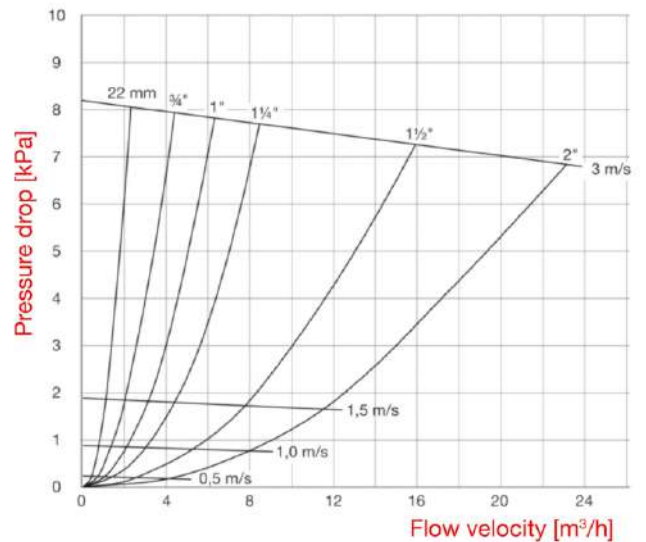

Find more information online:[Installation and operating instruction](#)[Statement of Conformity](#)[Flamcovent Smart ADSK](#)[Flamcovent Smart ADSK Revit](#)[Flamcovent Smart DWG](#)[Flamcovent Smart STEP](#)[Export catalogue](#)[Brochure](#)[Specification Text](#)[Packaging data](#)[Flamcovent & Clean Smart](#)

Fort Blauwkapel 1
1358 DB, Almere - nl

T +31 (0)36 52 62 300
E info@aalberts-hfc.com
I flamcogroup.com