



Cert. n° 0545

Compliant
with ERP 2015
Regulation (EU)
No. 327/2011



Heating / Air Conditioning
Comfort Circular Unit Heater
Polaris Air Conditioner



SABIANA
IL CLIMA AMICO

A leading brand of  **AFG**

Vertical discharge circular unit heaters

For all factory premises, either commercial or industrial, the efficient “COMFORT SABIANA” vertical discharge circular unit heater offers a practical and economical solution for space heating. They are available in ten sizes to a total of 100 various models for use with either Steam or Hot Water heating mediums, ranging in output from 13 kW to 200 kW depending upon the medium. Tests at 23 bars, they are suitable for use on Water with a working pressure of 10 bars and on Steam with a working pressure of 6 bars.

CASING

The casing is made of spun steel on both top and bottom sections and is designed to give greater strength and quieter operation. The casing is then phosphatised and finished with an epoxy polyester powder coating of light grey, RAL 9002, thus ensuring its continued attractive appearance. These top and bottom sections are assembled by means of threaded tie-rods, thus enabling the unit to be rapidly dismantled for maintenance etc.

HEAT EXCHANGER

The circular heat exchanger of the “COMFORT SABIANA” unit heater is constructed of copper tubes with aluminium fins. The supply and return connections are located on the top and bottom of the unit respectively and are positioned on the same side for simplicity of installation.

HELICOIDAL FAN

The helicoidal fan is statically and dynamically balanced, the rational high-capacity profile provides maximum air volume with a minimum power consumption.

SUSPENSION

Four eye bolts are provided on the unit for suspension by means of chains or tie-rods. These can also be used for more permanent bracketry of the customers’ choice.

ELECTRIC MOTOR

Standard motors are three phase 400 V, closed frame, flange mounted, pre-greased bearings. Available with:
 – single speed at 4 and 6 pole (IP44).
 – double speed double wiring at 4/6 pole (IP44).
 – two speed Delta-Star motors at 6/8 pole (IP55).



D.R.A. RADIAL LOUVRE

Is the model most commonly used: made up of eight separately adjustable large louvres, so shaped as to be able to cover the whole of the outlet area and therefore adaptable for minimum to maximum heights. This diffuser allows the air to be directed more easily to the areas where it is required the most, or conversely, if you do not require air to one particular corner you can close down one, two or three vanes and restrict the distribution.



T2 TWO WAY DIFFUSER

Is designed to give a two way or corridor distribution, suitable for corridor or gangway areas, between storage racks etc., generally mounted at any height dependant upon the length of corridor required.



The descriptions and illustrations provided in this publication are not binding: Sabiana reserves the right, whilst maintaining the essential characteristics of the types described and illustrated, to make, at any time, without the requirement to promptly update this piece of literature, any changes that it considers useful for the purpose of improvement or for any other manufacturing or commercial requirements.

Reference code eg: 6 Z 4 15

6	Z	4	15
6 POLES (900 r.p.m.)	TYPE COMFORT	SIZE	N° OF CIRCUITS

Dimension, weight and water content

D.R.A. radial louvre

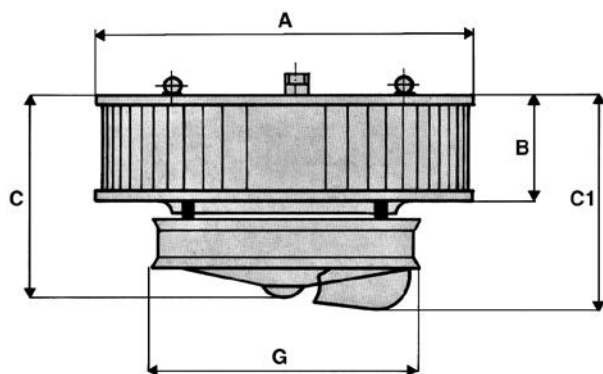

T2 two way diffuser

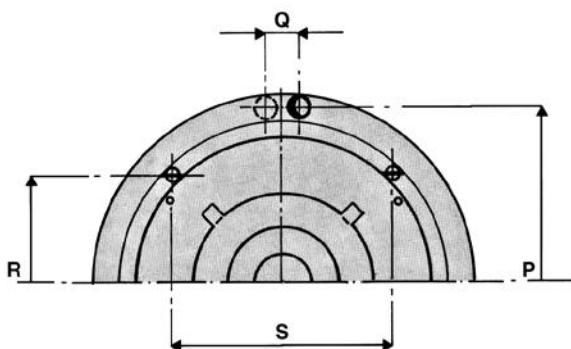
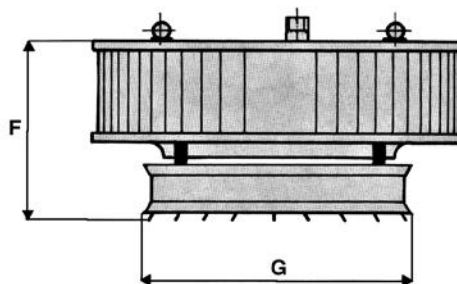

Version with PN 16 flanges

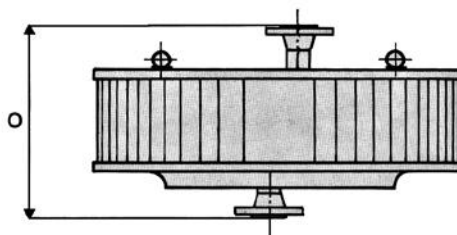

SIZE	A	B	C	C1	F	G	O	P	Q	R	S	Connections	Weight	Water content
												Ø	kg	Liters
0	680	180	430	560	380	560	331	612	62	350	350	1" ¼	31	1,20
1	780	180	430	560	380	560	331	702	62	421	421	1" ¼	36	1,30
2	780	280	530	660	480	560	431	702	62	421	421	1" ¼	42	1,90
3	880	280	530	700	480	660	435	802	68	491	491	1" ½	52	2,40
4	880	380	630	760	580	660	535	802	68	491	491	1" ½	58	3,20
5	1080	380	630	870	580	760	539	1005	80	755	440	2"	75	4,30
6	1080	455	705	945	655	760	614	1005	80	755	440	2"	85	5,20
7	1080	555	805	1045	755	760	714	1005	80	755	440	2"	95	5,90
8	1080	555	815	1055	765	760	714	1005	80	755	440	2"	97	5,90
9	1080	605	865	1105	815	760	765	1005	80	755	440	2"	106	6,50

The units with steam batteries are supplied with connections for welding; on request they can be supplied with flanges.

Operation limits

WATER:

- Maximum hot water temperature = max. 140°C
- Maximum working pressure = 10 bars

STEAM:

- Maximum working pressure = 6 bars

Mounting heights and area of air distribution

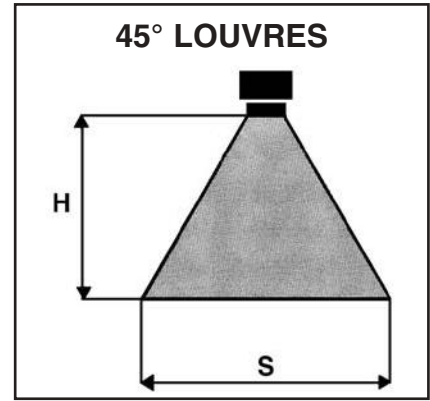
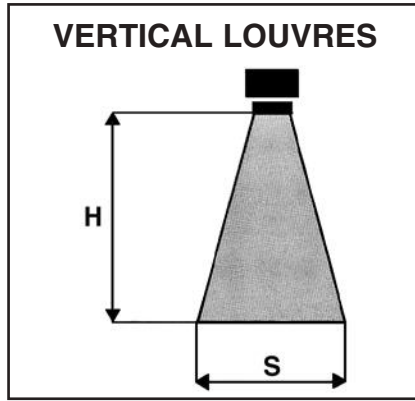
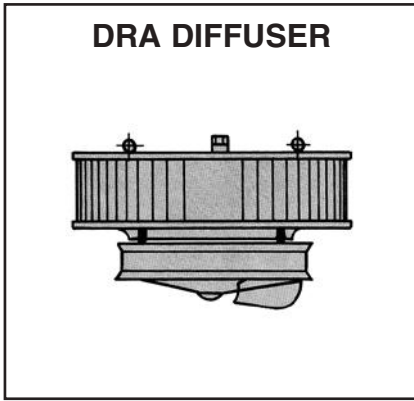

SIZE	1400 r.p.m.				900 r.p.m.			
	45° LOUVRES		VERTICAL LOUVRES		45° LOUVRES		VERTICAL LOUVRES	
	H height m.	S diameter m.	H height m.	S diameter m.	H height m.	S diameter m.	H height m.	S diameter m.
0	3 ÷ 5	15 ÷ 21	4 ÷ 6	7.5 ÷ 10.5	2.5 ÷ 4	10.5 ÷ 16.5	3.5 ÷ 5	6 ÷ 9
1	3.5 ÷ 5.5	16.5 ÷ 24	4.5 ÷ 6.5	9 ÷ 12	3 ÷ 4.5	12 ÷ 18	4 ÷ 5.5	7.5 ÷ 10.5
2	4 ÷ 6	18 ÷ 25.5	5 ÷ 7	10.5 ÷ 13.5	3 ÷ 5	12 ÷ 19.5	4.5 ÷ 6.5	9 ÷ 12
3	4 ÷ 6.5	18 ÷ 27	5.5 ÷ 8	10.5 ÷ 15	3.5 ÷ 5.5	15 ÷ 22.5	5 ÷ 7	9 ÷ 13.5
4	4 ÷ 7	18 ÷ 28.5	6 ÷ 9	10.5 ÷ 16.5	3.5 ÷ 6	15 ÷ 24	5.5 ÷ 8	10.5 ÷ 15
5	—	—	—	—	4 ÷ 6.5	16.5 ÷ 25.5	5.5 ÷ 8.5	10.5 ÷ 15
6	—	—	—	—	4 ÷ 8	16.5 ÷ 28.5	6 ÷ 10	12 ÷ 18
7	—	—	—	—	4 ÷ 8	16.5 ÷ 28.5	6 ÷ 10	12 ÷ 18
8	—	—	—	—	5 ÷ 11	18 ÷ 31.5	6.5 ÷ 14	13.5 ÷ 19.5
9	—	—	—	—	5 ÷ 11	18 ÷ 33	6.5 ÷ 14	13.5 ÷ 21

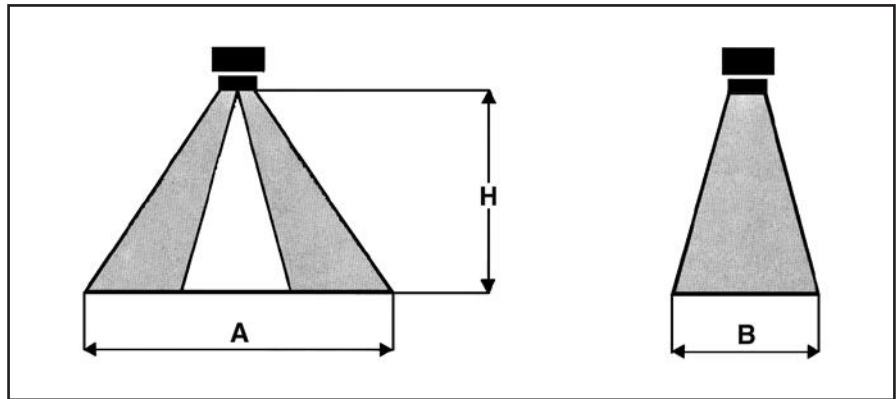
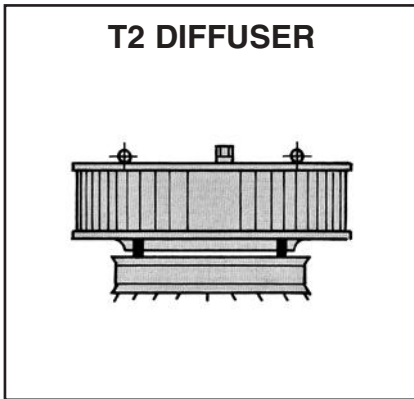

SIZE	1400 r.p.m.		900 r.p.m.	
	H height m.	ZONE A B m.	H height m.	ZONE A B m.
0	3 ÷ 6	15x6 ÷ 10x4	2.5 ÷ 5	13x5 ÷ 9x4
1	3 ÷ 6	16x7 ÷ 10x5	2.5 ÷ 5	14x6 ÷ 10x4
2	3.5 ÷ 7	18x8 ÷ 14x5	3 ÷ 6	16x7 ÷ 10x4
3	3.5 ÷ 8	20x10 ÷ 14x6	3 ÷ 6.5	17x8 ÷ 13x5
4	4 ÷ 9	22x10 ÷ 15x7	3.5 ÷ 7	20x10 ÷ 15x5
5	—	—	4 ÷ 8	22x10 ÷ 16x5
6	—	—	4 ÷ 10	24x10 ÷ 18x6
7	—	—	4 ÷ 11	24x11 ÷ 20x8
8	—	—	6 ÷ 15	26x12 ÷ 22x10
9	—	—	6 ÷ 15	26x12 ÷ 22x10

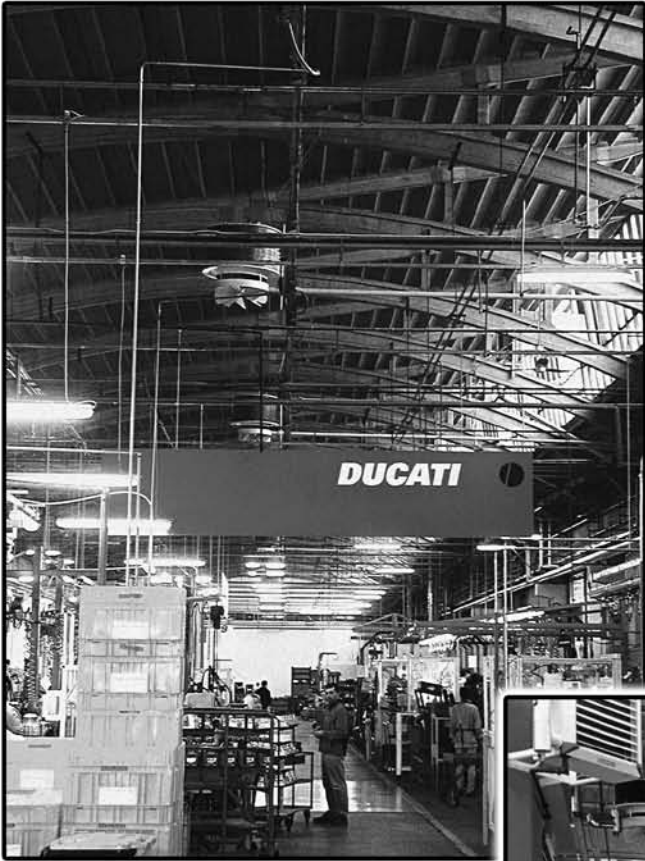

Tab. 1 Water 85-75°C Drop 10°C Entering air temperature 15°C
--

Tab. 2 Water 85-70°C Drop 15°C Entering air temperature 15°C
--

Thermal emission

Speed r.p.m.	Size	Air flow m³/h	Noise level dB(A) * (at 5 m)	Model
1400	0	3.000	56	4Z-007
	1	3.400	60	4Z-107
	2	5.100	63	4Z-211
	3	6.000	65	4Z-311
	4	7.800	66	4Z-415
900	0	2.000	48	6Z-007
	1	2.400	52	6Z-107
	2	3.700	54	6Z-211
	3	4.400	55	6Z-311
	4	5.700	56	6Z-415
	5	7.100	63	6Z-515
	6	9.000	64	6Z-618
	7	9.900	65	6Z-722
	8	11.000	65	6Z-822
9	12.000	66	6Z-924	

Thermal emission kW	Leaving air temperature °C
24.4	39
28.4	39
41.8	39
48.8	39
64.4	39
19.1	43
22.1	42
32.7	41
38.0	40
50.2	41
61.5	40
77.8	40
92.0	42
107.0	44
115.1	44

Thermal emission kW	Leaving air temperature °C
22.7	37
26.1	37
38.9	37
45.3	37
59.9	37
17.7	41
20.4	40
30.3	39
35.3	38
46.7	39
57.1	39
72.2	38
85.6	40
99.5	42
106.7	42

* = The sound pressure levels dB(A) are measured at a distance of 5m, directional factor Q = 2, compliant with the EN 3744 standard.

Correction factors

ON REQUEST: double speed motor,
single tension, double wiring,
1400/900 r.p.m. or 900/700 r.p.m.

Thermal emission

with motor running at 700 r.p.m.:

Watt = 0.85 x Watt with motor at 900 r.p.m.

Air = 0.70 x air flow with motor at 900 r.p.m.

Entering air temperature °C	Water			
	75/65	80/70	85/75	90/80
+ 5	1.00	1.07	1.15	1.23
+ 10	0.92	1.00	1.07	1.15
+ 15	0.84	0.92	1.00	1.07
+ 20	0.76	0.84	0.92	1.00
+ 25	0.69	0.76	0.84	0.92
+ 30	0.61	0.69	0.76	0.84

Entering air temperature °C	Water			
	80/65	85/70	90/75	95/80
+ 5	1.07	1.15	1.23	1.32
+ 10	1.00	1.07	1.15	1.23
+ 15	0.92	1.00	1.07	1.15
+ 20	0.84	0.92	1.00	1.07
+ 25	0.76	0.84	0.92	1.00
+ 30	0.69	0.76	0.84	0.92

Thermal emission

Speed r.p.m.	Size	Air flow m ³ /h	Noise level dB(A) * (at 5 m)	Model
1400	0	3.000	56	4Z-007
	1	3.400	60	4Z-107
	2	5.100	63	4Z-211
	3	6.000	65	4Z-311
	4	7.800	66	4Z-415
900	0	2.000	48	6Z-007
	1	2.400	52	6Z-107
	2	3.700	54	6Z-211
	3	4.400	55	6Z-311
	4	5.700	56	6Z-415
	5	7.100	63	6Z-515
	6	9.000	64	6Z-618
	7	9.900	65	6Z-722
	8	11.000	65	6Z-822
	9	12.000	66	6Z-924

Tab. 3
Water 90-70°C
Drop 20°C
Entering air temperature 15°C

Thermal emission kW	Leaving air temperature °C
22.9	37
26.5	38
39.3	38
45.8	37
60.6	38
17.8	41
20.5	40
30.6	39
35.6	39
47.1	38
57.5	39
72.9	39
86.4	41
100.5	42
107.8	42

Tab. 4
Water 120-100°C
Drop 20°C
Entering air temperature 15°C

Thermal emission kW	Leaving air temperature °C
32.5	48
37.8	48
55.9	48
65.2	48
86.3	48
25.3	53
29.3	52
43.5	51
50.7	50
67.1	51
82.0	50
103.8	50
123.0	53
142.8	54
153.3	54

* = The sound pressure levels dB(A) are measured at a distance of 5m, directional factor Q = 2, compliant with the EN 3744 standard.

Correction factors

ON REQUEST: double speed motor,
single tension, double wiring,
1400/900 r.p.m. or 900/700 r.p.m.

Thermal emission
with motor running at 700 r.p.m.:

Watt = 0.85 x Watt with motor at 900 r.p.m.

Air = 0.70 x air flow with motor at 900 r.p.m.

Entering air temperature °C	Water			
	80/60	85/65	90/70	95/75
+ 5	1.00	1.07	1.15	1.23
+ 10	0.92	1.00	1.07	1.15
+ 15	0.84	0.92	1.00	1.07
+ 20	0.76	0.84	0.92	1.00
+ 25	0.69	0.76	0.84	0.92
+ 30	0.61	0.69	0.76	0.84

Entering air temperature °C	Water			
	110/90	120/100	130/110	140/120
+ 5	1.00	1.10	1.21	1.31
+ 10	0.92	1.05	1.15	1.26
+ 15	0.89	1.00	1.10	1.21
+ 20	0.84	0.94	1.05	1.15
+ 25	0.78	0.89	1.00	1.10
+ 30	0.73	0.84	0.94	1.05

Tab. 5 Water 130-100°C Drop 30°C Entering air temperature 15°C
--

Tab. 6 Water 140-100°C Drop 40°C Entering air temperature 15°C
--

Thermal emission

Speed r.p.m.	Size	Air flow m ³ /h	Noise level dB(A) * (at 5 m)	Model
1400	0	3.000	56	4Z-007
	1	3.400	60	4Z-107
	2	5.100	63	4Z-211
	3	6.000	65	4Z-311
	4	7.800	66	4Z-415
900	0	2.000	48	6Z-007
	1	2.400	52	6Z-107
	2	3.700	54	6Z-211
	3	4.400	55	6Z-311
	4	5.700	56	6Z-415
	5	7.100	63	6Z-515
	6	9.000	64	6Z-618
	7	9.900	65	6Z-722
	8	11.000	65	6Z-822
9	12.000	66	6Z-924	

Thermal emission kW	Leaving air temperature °C
34.5	50
39.9	51
59.2	51
69.0	50
91.3	51
26.1	55
30.9	55
46.1	54
53.7	53
70.9	53
86.7	53
109.8	53
130.2	56
151.4	58
162.5	57

Thermal emission kW	Leaving air temperature °C
35.3	51
40.9	52
60.8	52
70.9	51
93.7	52
27.4	57
31.8	56
47.3	54
55.1	54
73.0	55
89.1	54
112.8	54
133.7	57
155.2	60
166.5	59

* = The sound pressure levels dB(A) are measured at a distance of 5m, directional factor Q = 2, compliant with the EN 3744 standard.

Correction factors

ON REQUEST: double speed motor,
single tension, double wiring,
1400/900 r.p.m. or 900/700 r.p.m.

Thermal emission
with motor running at 700 r.p.m.:
Watt = 0.85 x Watt with motor at 900 r.p.m.
Air = 0.70 x air flow with motor at 900 r.p.m.

Entering air temperature °C	Water			
	110/80	120/90	130/100	140/110
+ 5	0.90	1.00	1.10	1.19
+ 10	0.85	0.94	1.04	1.14
+ 15	0.79	0.90	1.00	1.10
+ 20	0.74	0.85	0.94	1.04
+ 25	0.69	0.79	0.90	1.00
+ 30	0.65	0.74	0.85	0.94

Entering air temperature °C	Water	
	130/90	140/100
+ 5	1.00	1.09
+ 10	0.95	1.04
+ 15	0.90	1.00
+ 20	0.85	0.95
+ 25	0.80	0.90
+ 30	0.76	0.85

Thermal emission

Speed r.p.m.	Size	Air flow m ³ /h	Noise level dB(A) * (at 5 m)	Model
1400	0	3.000	56	4Z-007
	1	3.400	60	4Z-107
	2	5.100	63	4Z-211
	3	6.000	65	4Z-311
	4	7.800	66	4Z-415
900	0	2.000	48	6Z-007
	1	2.400	52	6Z-107
	2	3.700	54	6Z-211
	3	4.400	55	6Z-311
	4	5.700	56	6Z-415
	5	7.100	63	6Z-515
	6	9.000	64	6Z-618
	7	9.900	65	6Z-722
	8	11.000	65	6Z-822
	9	12.000	66	6Z-924

Tab. 7
Steam 0.5 bar
Entering air temperature 15°C

Thermal emission kW	Leaving air temperature °C
37.3	53
43.1	54
64.8	54
73.7	53
97.9	54
31.0	63
37.1	63
55.3	62
62.0	59
82.9	60
98.3	58
124.4	58
150.9	62
171.5	62
184.0	62

Tab. 8
Steam 3 bar
Entering air temperature 15°C

Thermal emission kW	Leaving air temperature °C
49.6	68
57.3	68
86.0	68
98.0	66
130.2	67
41.3	79
49.3	79
72.9	77
82.4	73
110.2	75
130.8	73
165.5	73
200.7	78
228.0	79
245.0	79

* = The sound pressure levels dB(A) are measured at a distance of 5m, directional factor Q = 2, compliant with the EN 3744 standard.

Correction factors

ON REQUEST: double speed motor,
single tension, double wiring,
1400/900 r.p.m. or 900/700 r.p.m.

Thermal emission
with motor running at 700 r.p.m.:

Watt = 0.85 x Watt with motor at 900 r.p.m.

Air = 0.70 x air flow with motor at 900 r.p.m.

Entering air temperature °C	Steam Bar			
	0.3	0.5	1	2
+ 5	1.06	1.10	1.19	1.33
+ 10	1.00	1.05	1.14	1.28
+ 15	0.95	1.00	1.09	1.23
+ 20	0.90	0.94	1.03	1.17
+ 25	0.85	0.89	0.98	1.12
+ 30	0.79	0.84	0.93	1.07

Entering air temperature °C	Steam Bar			
	3	4	5	6
+ 5	1.06	1.10	1.13	1.16
+ 10	1.03	1.06	1.10	1.13
+ 15	1.00	1.03	1.06	1.10
+ 20	0.96	1.00	1.03	1.06
+ 25	0.93	0.96	1.00	1.03
+ 30	0.89	0.93	0.96	1.00

Sabiana Polaris suspended circular air conditioners provide a simple solution to centralised air conditioning systems offering the following advantages:

- Simple installation
- Low equipment cost
- Low user running cost
- Flexibility in installation and project design
- High capacity fans for distribution of cooling and heating systems for large commercial and industrial buildings
- Minimum space is required for the units which can be suspended from the building roof supports, therefore not taking up valuable floor space, this type of unit also dispenses with expensive and cumbersome duct work systems.

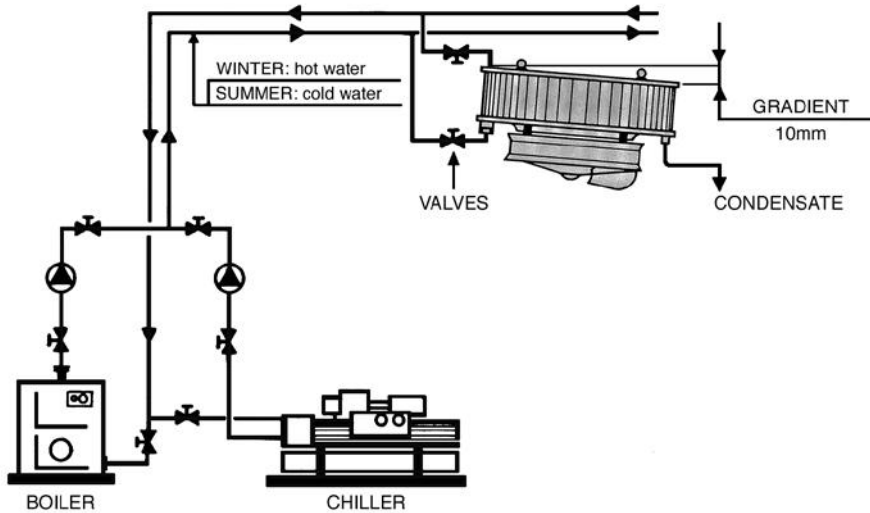

The Sabiana Polaris Range of air conditioners can be matched to the Sabiana Krio Range of indoor and outdoor chillers and heat pumps.

On cooling when the fan is inactive for long periods, it is required to shut off the chilled water supply to the coil using 2/3-way valves, electrically connected to the thermostatic control, to avoid condensation forming on the outside of the unit (see electric diagram on page 15).

Description

CASING

The casing is made of spun steel on both top and bottom sections which is designed to give greater strength and quieter operation. The casing is then phosphatised and finished with an epoxy polyester powder coating of light grey, RAL 9002, thus ensuring its continued attractive appearance. These top and bottom sections are assembled by means of threaded tie-rods, thus enabling the unit to be rapidly dismantled for maintenance etc.

HEAT EXCHANGER

The circular heat exchanger of the "POLARIS SABIANA" air conditioner is constructed of copper tubes with aluminium fins. The supply and return connections are located on the top and bottom of the unit respectively and are positioned on the same side for simplicity of installation.

Tests at 23 bars, they are suitable for use on Water with a working pressure of 10 bars. The coil is not suitable for use in corrosive atmosphere or in environments where aluminium may be subject to corrosion.

ELECTRIC MOTOR

Standard motors are three phase with closed frame, flange mounted, pre-greased bearings. The units are supplied as standard with **two speed Delta-Star motors, 6/8 poles, three phase, 400 V, with Klixon thermic protection.**

HELICOIDAL FAN

The helicoidal fan is statically and dynamically balanced, the rational high-capacity profile provides maximum air volume with a minimum power consumption.

SUSPENSION

Four eye bolts are provided on the unit for suspension by means of chains or tie-rods. These can also be used for more permanent bracketry of the customers' choice.



D.R.A. RADIAL LOUVRE

Is the model most commonly used: made up of eight separately adjustable large louvre, so shaped as to be able to cover the whole of the outlet area and therefore adaptable for minimum to maximum heights. This diffuser allows the air to be directed more easily to the areas where it is required the most, or conversely, if you do not require air to one particular corner you can close down one, two or three vanes and restrict the distribution.

Mounting heights and area of air diffusion

Size	Model	Mounting heights (m)		Area of air distribution (m)
		"DRA" diffuser		"DRA" diffuser max.
		min.	max.	
0	P.007	2,5	5,0	11
1	P.107	3,0	5,5	12
3	P.311	3,5	7,0	15
4	P.415	3,5	8,0	16
5	P.515	4,0	8,5	17
6	P.618	4,0	9,0	18
7	P.722	4,0	9,0	19
8	P.822	5,0	14,0	21
9	P.924	5,0	14,0	22

Dimension, weight and water contents

DRA diffuser

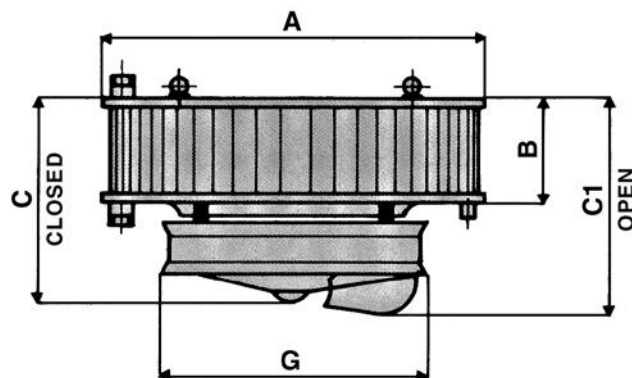

Size	Model	A	B	C	C1	G	Connections	Weight	Water content
							Ø	kg	Liters
0	P.007	680	180	430	560	560	1" ¼	31	1,20
1	P.107	780	180	430	560	560	1" ¼	36	1,30
3	P.311	880	280	530	700	660	1" ½	52	2,40
4	P.415	880	380	630	760	660	1" ½	58	3,20
5	P.515	1.080	380	630	870	760	2"	75	4,30
6	P.618	1.080	455	705	845	760	2"	85	5,20
7	P.722	1.080	555	805	1.045	760	2"	95	5,90
8	P.822	1.080	555	815	1.055	760	2"	97	5,90
9	P.924	1.080	605	865	1.055	760	2"	106	6,50

Operation limits

WATER:

- Maximum hot water temperature = max. 140°C
- Minimum chilled water temperature = min. 7°C
- Maximum working pressure = 10 bars

Technical characteristics

Size	Model	Noise level dB(A) * (at 5 m)		Air flow m ³ /h		Heating: water temp. 85/70°C, entering air temp. 15°C				Cooling: 55% R.H. entering air temp. 28°C, water temp. 11/15°C	
		900 r.p.m.	700 r.p.m.	900 r.p.m.	700 r.p.m.	kW		L.A.T. °C		kW	
						900 r.p.m.	700 r.p.m.	900 r.p.m.	700 r.p.m.	900 r.p.m.	700 r.p.m.
0	P.007	48	46	2.000	1.400	17,6	15,1	41	47	3,1	2,7
1	P.107	52	49	2.400	1.680	20,4	17,4	40	46	4,0	3,5
3	P.311	55	52	4.400	3.080	35,3	30,0	38	44	7,5	6,6
4	P.415	56	53	5.700	4.000	46,7	39,6	39	44	10,9	9,5
5	P.515	63	58	7.100	4.970	57,1	48,5	39	44	13,6	11,9
6	P.618	64	59	9.000	6.300	72,2	61,4	38	44	17,2	15,0
7	P.722	65	60	9.900	6.930	85,6	72,7	40	46	18,9	16,5
8	P.822	65	60	11.000	7.700	99,5	84,5	43	48	22,0	19,0
9	P.924	66	61	12.000	8.400	106,7	90,7	42	47	23,7	20,6

* = Pressione sonora dB(A) riferita ad una distanza di 5m, fattore direzionale Q = 2, conforme alla norma EN 3744.

Correction factors for different conditions on heating

Entering air temp. °C	Δt water 10°C			Δt water 15°C			Δt water 20°C		
	90°/80°	80°/70°	70°/60°	90°/75°	85°/70°	80°/65°	110°/90°	100°/80°	90°/70°
5	1,28	1,17	0,96	1,24	1,16	1,08	1,52	1,36	1,20
10	1,20	1,08	0,88	1,16	1,08	1,00	1,44	1,28	1,12
15	1,12	0,99	0,80	1,08	1,00	0,92	1,36	1,20	1,04
20	1,04	0,90	0,72	1,00	0,92	0,84	1,28	1,12	0,96
25	0,96	0,81	0,64	0,92	0,84	0,76	1,20	1,04	0,88

Correction factors for different conditions on cooling

Entering air temp. 55% R.H.	Δt water 5°C			Δt water 4°C		
	7°/12°	9°/14°	10°/15°	9°/13°	10°/14°	11°/15°
26°C	1,10	0,98	0,92	1,00	0,93	0,86
27°C	1,16	1,03	0,98	1,06	1,00	0,93
28°C	1,23	1,10	1,03	1,13	1,06	1,00
29°C	1,30	1,16	1,10	1,20	1,13	1,06
30°C	1,37	1,23	1,16	1,26	1,20	1,13

Do not supply the air conditioners with water at temperature lower than 7°C.

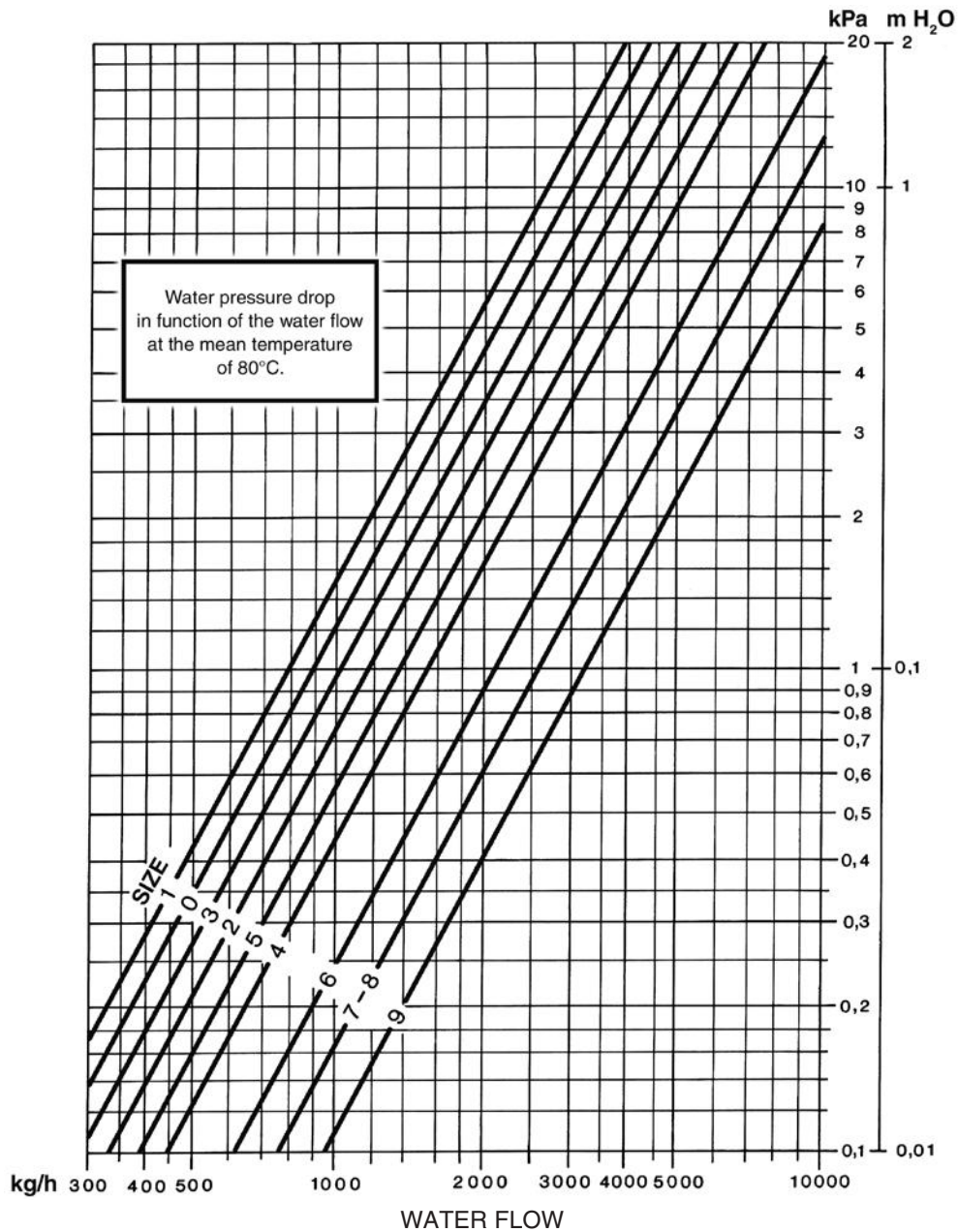

Correction factors for temperatures different from 80°C

10°	15°	65°	70°	75°	80°	85°	90°	95°	100°	105°
1,41	1,31	1,07	1,05	1,02	1	0,97	0,95	0,92	0,89	0,86

**Comfort and Polaris
installation instructions**

- On cooling when the fan is inactive for long periods, it is required to shut off the chilled water supply to the coil using 2/3-way valves, electrically connected to the thermostatic control, to avoid condensation forming on the outside of the unit.
- When installing the Comfort / Polaris appliances, a free space of around 50 cm must be left from the ceiling, so as to allow the necessary maintenance.

Single speed, single wiring motors

Size	Poles	r.p.m.	Motor type	Power W	Absorption A
0	4	1.400	71/4	120	0.35
	6	900	71/6	40	0.17
1	4	1.400	71/4	120	0.35
	6	900	71/6	40	0.17
2	4	1.400	71/4	220	0.60
	6	900	71/6	75	0.30
3	4	1.400	80/4	550	1.60
	6	900	80/6	370	1.30
4	4	1.400	80/4	550	1.60
	6	900	80/6	370	1.30
5	6	900	80/6	370	1.30
6	6	900	80/6	370	1.30
7	6	900	80/6	370	1.30
8	6	900	80/6	550	1.70
9	6	900	80/6	550	1.70

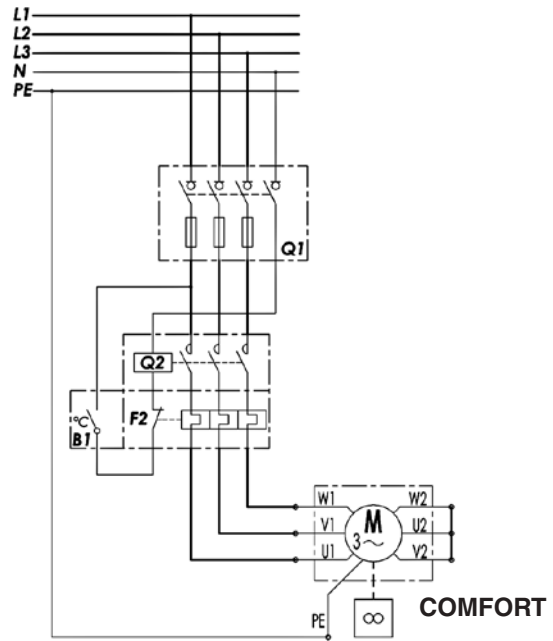

LEGEND:

- Q1 Four poles Circuit Breakers with three poles protected by fuses
- Q2 Motor insertion power switch
- Q3 Motor high speed insertion power switch
- Q4 Motor low speed insertion power switch
- F1 Control circuit thermal protection
- F2 Thermal protection (Power switch Q2/Q3)
- F3 Thermal protection (Power switch Q4)
- S2 Speed commutation switch
- B1 Ambient thermostat

Double speed, double wiring motors

Size	Poles	r.p.m.	Motor type	Power W	Absorption A
0	4/6	1.400/900	71/46	115/45	0.40/0.20
1	4/6	1.400/900	71/46	115/45	0.40/0.20
2	4/6	1.400/900	71/46	205/75	0.70/0.30
3	4/6	1.400/900	80/46	370/150	1.10/0.60
4	4/6	1.400/900	80/46	370/150	1.10/0.60

Protect each motor with a motor protector set to a value of 1.10 - 1.15 of the rating current of the motor.

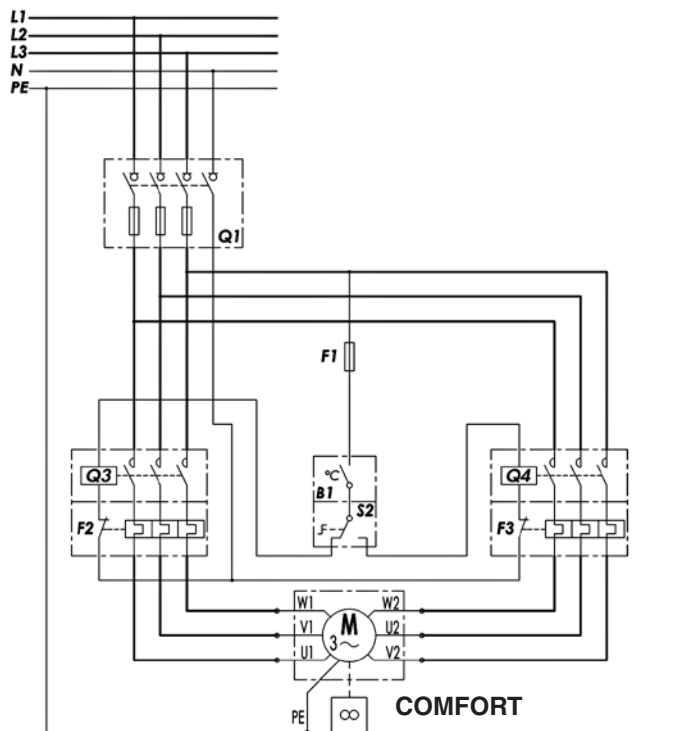

Speed commutation switch - Code 3021043

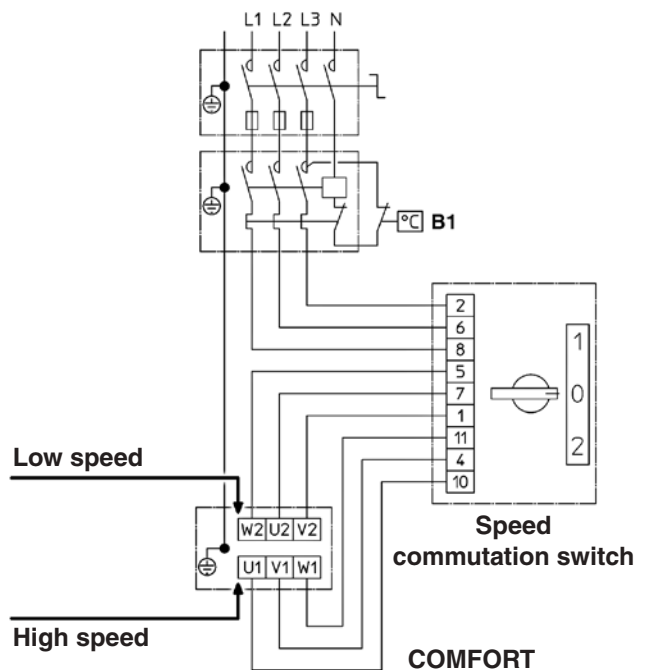

Electric motors characteristics

Two speed Delta-Star motors, 6/8 poles, three phase, 400 V, with Klixon thermic protection

Comfort circular unit heaters and Polaris air conditioners are equipped with 6/8 poles electric motors.

With these motors it is possible to reduce the speed changing the connection from delta to star.

They are three phase, single voltage, 400V – 50Hz, protection IP 55, with klixon thermic protection.

It is suggested that the electric connection is made in accordance with the diagram shown below.

Size	Identification	Speed r.p.m.		Power W		Absorption A	
		Δ	Y	Δ	Y	Δ	Y
Comfort / Polaris							
0	FCZ01/71-68S	930	800	75	50	0,21	0,10
1	FCZ01/71-68S	930	800	75	50	0,21	0,10
3	FCZ34/80-68S	940	800	215	180	0,48	0,31
4	FCZ34/80-68S	940	800	215	180	0,48	0,31
5	FCZ59/90-68S	930	800	650	480	1,50	1,00
6	FCZ59/90-68S	930	800	650	480	1,50	1,00
7	FCZ59/90-68S	930	800	650	480	1,50	1,00
8	FCZ59/90-68S	930	800	650	480	1,50	1,00
9	FCZ59/90-68S	930	800	650	480	1,50	1,00

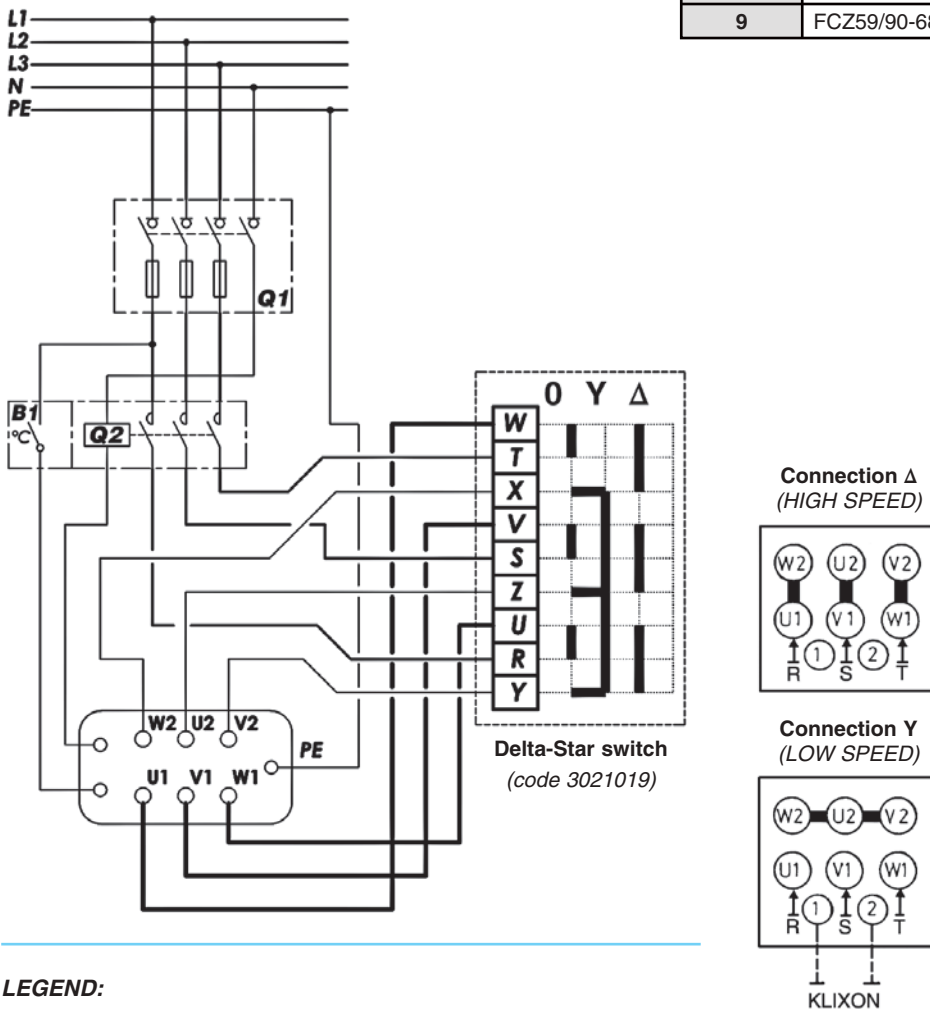

LEGEND:

- B1 Ambient thermostat
- Q1 Four poles Circuit Breakers with three poles protected by fuses
- Q2 Motor insertion power switch

**Multi-function automatic control panel
for two speed Delta-Star motors, 6/8 poles, three phase, 400 V,
with Klixon thermic protection**

IDENTIFICATION	CODE
BSA-B	9007651
BSA-A	9007652
BSA-D	9007653

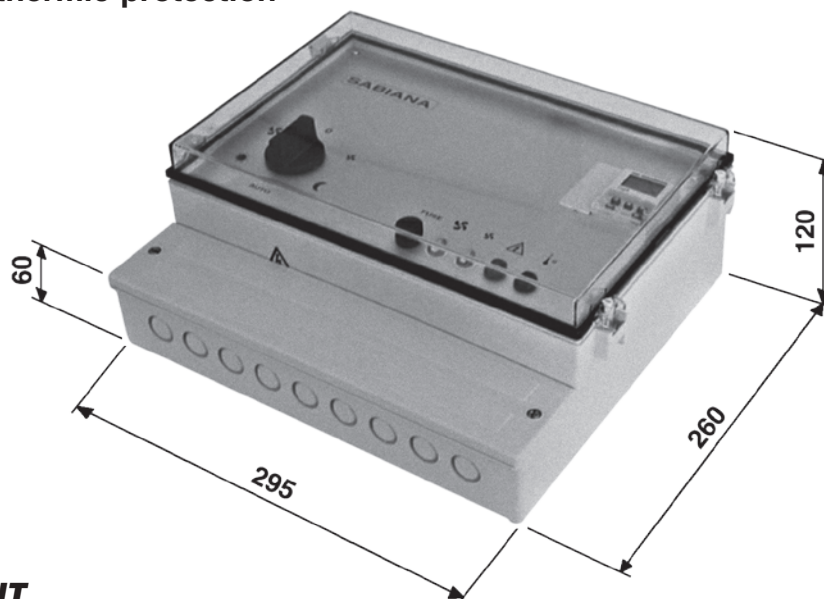

IMPORTANT

**THIS DEVICE IS NOT SUITABLE
FOR EX AMBIENT OR FOR THE CONTROL OF SINGLE-PHASE MOTORS.**

Description

Wall mounting plastic container complete with transparent door.

The front panel includes:

- control switch;
- timer / by-pass switch;
- signal lights;
- auxiliary protection fuse carrier;
- timer compartment cover (accessory).

Versions

- **BSA-B** without timer (Code 9007651)
- **BSA-A** with manual daily timer (Code 9007652)
- **BSA-D** with digital weekly timer (Code 9007653)

The basic version, BSA-B, is supplied without a timer, yet is ready to be fitted with this accessory if required.

Simply remove the timer cover, insert the timer chosen and connect it internally to the pre-installed wiring inside the control panel.

Technical specifications

- Wall control.
- Index of protection IP 40.
- Operating voltage 3 x 400V 50Hz.
- Control voltage 1 x 230V.
- Rated operating current 9 A 400V (AC3).

Application

Multi-position, multi-function switch for automatically controlling the speed of Sabiana unit heaters with two-speed, 400V three-phase motors.

Description

The control panel is supplied without a timer. The timer can be fitted after installation, by inserting it in the panel and connecting it electrically using the special pre-wired connector. Electromechanical daily timers and digital weekly timers are available.

Controls

Operation

- **Control switch on “0”**: disconnects power to the unit heaters and thus the unit heaters are off.
- **Control switch on “fan”**: continuous operation of the unit heater at low speed.
- **Control switch on “FAN”**: continuous operation of the unit heater at high speed.
- **Control switch on “AUTO”** (only for devices with timer, BSA-A and BSA-D): enables the automatic switching of the unit heater speed according to the status of an external 1- or 2-step thermostat. The timer can be combined with two different thermostats, with separate settings for night-time or daytime operation. **Using thermostats with changeover contacts allows automatic switching from low - high fan speed with the “day” thermostat, and low speed - fan off with the “night” thermostat.** Using two-step thermostats allows the speed of the unit heater to be switched automatically from high to low and to off when reaching the set temperature.
- **Function switch on “day”**: by-passes the timer and forces the connection to the “day” thermostat.
- **Function switch on “night”**: by-passes the timer and forces the connection to the “night” thermostat.

Anti-freeze function

The control is fitted for connection to an external room thermostat that is suitably set to a minimum required value. When the thermostat with anti-freeze function is connected, the control panel switches on the unit heater at low speed, even if the Control switch is on OFF.

Motor thermal overload devices

The Sabiana unit heater motors are fitted with internal TK thermal overload devices. The thermal overload device must be connected to the control panel, so that the latter automatically cuts off power to the unit heater if the overload is activated. If the control panel is connected to a series of unit heaters, the TK overload devices on each motor must be connected together in series, and then connected to the corresponding terminals on the control panel.

Electric connection

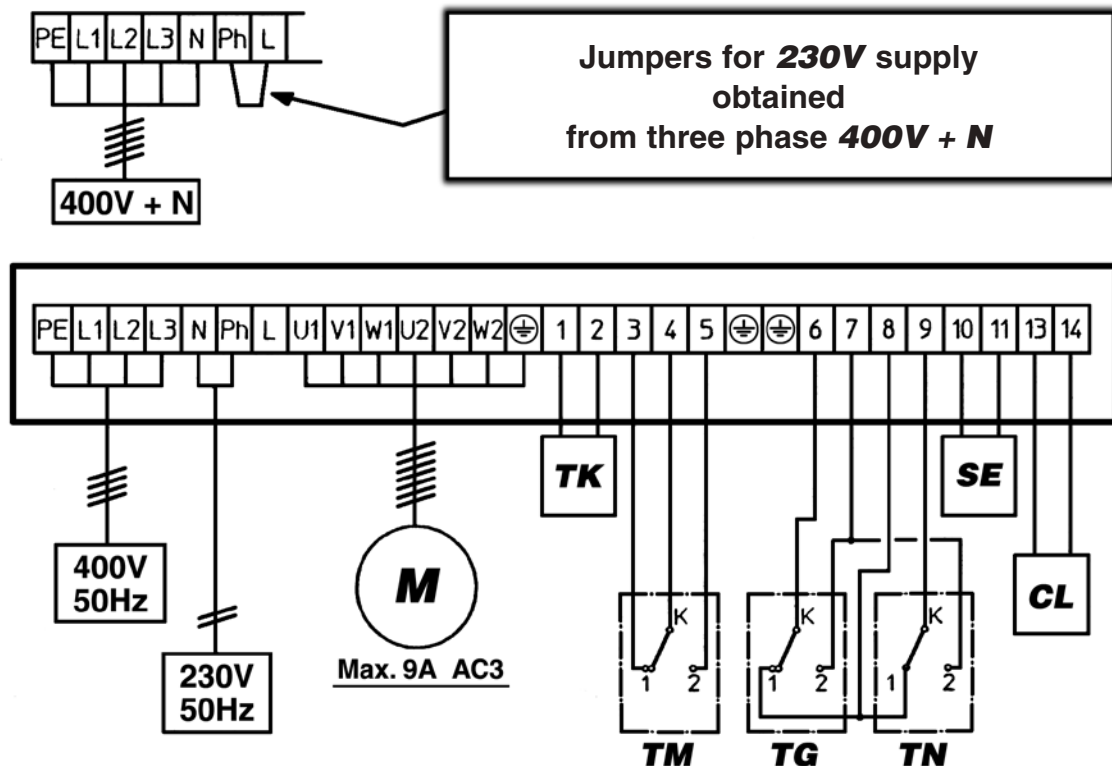

LEGEND:

M = Motor **TK** = Safety thermostat **TM** = Anti-frost thermostat **TG** = Day thermostat
TN = Night thermostat **SE** = Possible external switch **CL** = Extra connections

**Manual two-position switch
for two speed Delta-Star motors, 6/8 poles, three phase, 400 V,
with Klixon thermic protection**

IDENTIFICATION	CODE
BS 2S	9007654

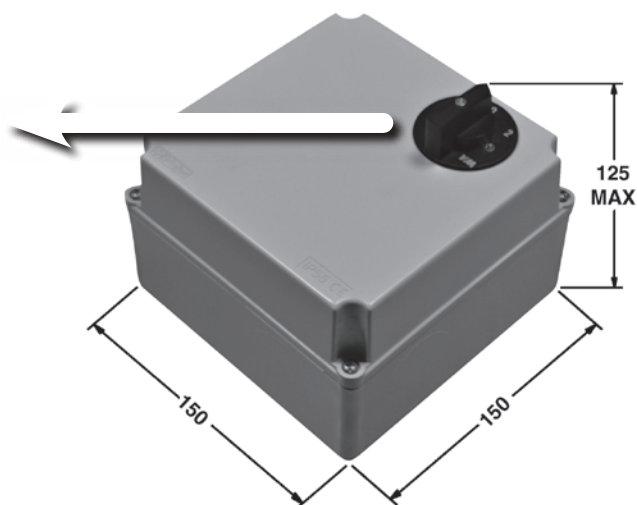
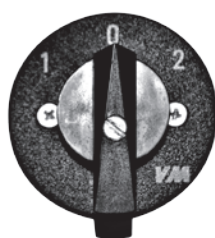

IMPORTANT

**THIS DEVICE IS NOT SUITABLE
FOR EX AMBIENT OR FOR THE CONTROL OF SINGLE-PHASE MOTORS.**

Description

Wall mounted plastic case, containing:

- 1 manual switch (1-0-2) for manually selecting the unit heater fan speed;
- 1 four pole control contactor;
- 1 voltage-free auxiliary contact used to control or lockout of external appliances.
- Terminal block for the connection of the unit heaters, motor overload devices and external thermostat.

Technical specifications

- Wall control.
- Index of protection IP 40.
- Operating voltage 3 x 400V 50Hz.
- Control voltage 1 x 230V.
- Rated operating current 9A 400V (AC3).

Applications

Switch for controlling the fan speed on one or more Sabiana unit heaters. The control can be connected to an external room thermostat.

Motor thermal overload devices

The Sabiana unit heater motors are fitted with internal TK thermal overload devices. The thermal overload device must be connected to the control panel, so that the latter automatically cuts off power to the unit heater if the overload is activated. If the control panel is connected to a series of unit heaters, the TK overload devices on each motor must be connected together in series, and then connected to the corresponding terminals on the control panel.

Electric connection

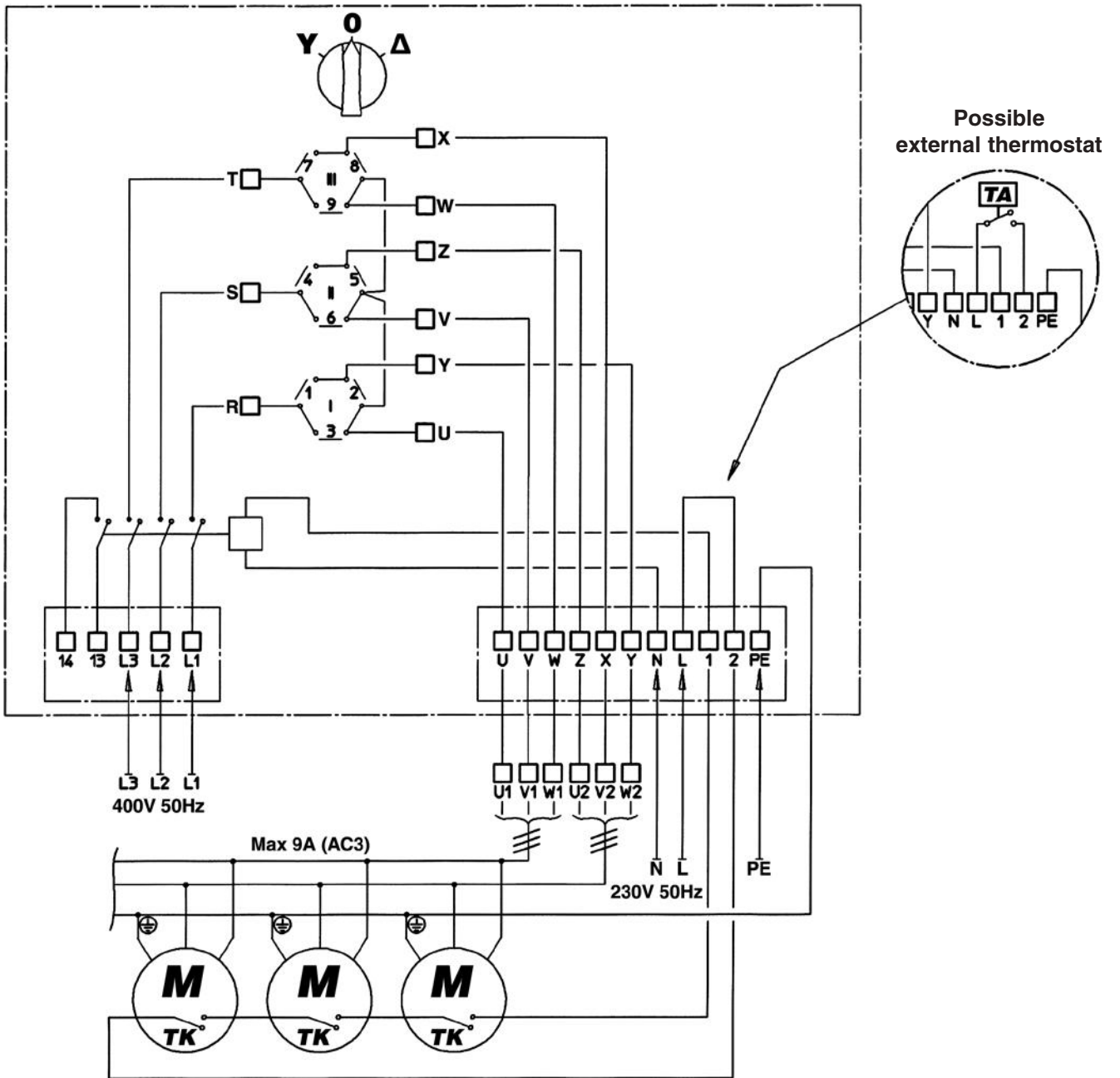

LEGEND:

- Y** = Low speed **Δ** = High speed **M** = Motor
TA = Room thermostat **TK** = Safety thermostat (Klixon)

**Manual two-position switch with thermostat
for two speed Delta-Star motors, 6/8 poles, three phase, 400 V,
with Klixon thermic protection**

IDENTIFICATION	CODE
BS 2-ST	9007655

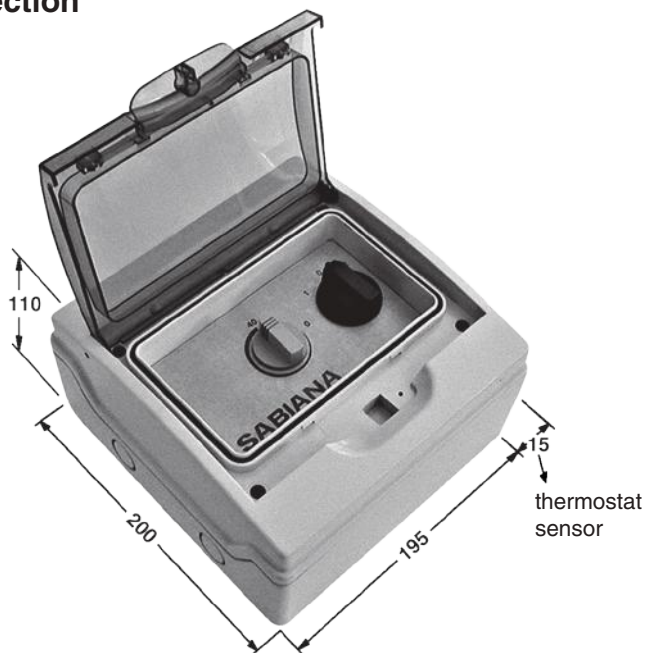

IMPORTANT

**THIS DEVICE IS NOT SUITABLE
FOR EX AMBIENT OR FOR THE CONTROL OF SINGLE-PHASE MOTORS.**

Description

Wall mounted plastic case, containing:

- 1 manual switch (1-0-2) for manually selecting the unit heater fan speed;
- 1 four pole control contactor;
- 1 voltage-free auxiliary contact used to control or lockout of external appliances;
- 1 room thermostat;
- Terminal block for the connection of the unit heaters, motor overload devices and external thermostat.

Technical specifications

- Wall control.
- Index of protection IP 40.
- Operating voltage 3 x 400V 50Hz.
- Control voltage 1 x 230V.
- Rated operating current 9A 400V (AC3).

Applications

Switch for controlling the fan speed on one or more Sabiana unit heaters, with built-in temperature control. Depending on the set room temperature, the control stops or starts the unit heaters at the speed selected on the speed switch. The bulb of the thermostat is positioned outside of the panel casing.

Motor thermal overload devices

The Sabiana unit heater motors are fitted with internal TK thermal overload devices. The thermal overload device must be connected to the control panel, so that the latter automatically cuts off power to the unit heater if the overload is activated. If the control panel is connected to a series of unit heaters, the TK overload devices on each motor must be connected together in series, and then connected to the corresponding terminals on the control panel.

Installation

Check that the position chosen for the installation of the panel does not affect the correct operation of the room thermostat. Avoid fastening the control panel to cold walls, in areas affected by cold/hot air currents or at an unusual height.

Electric connection

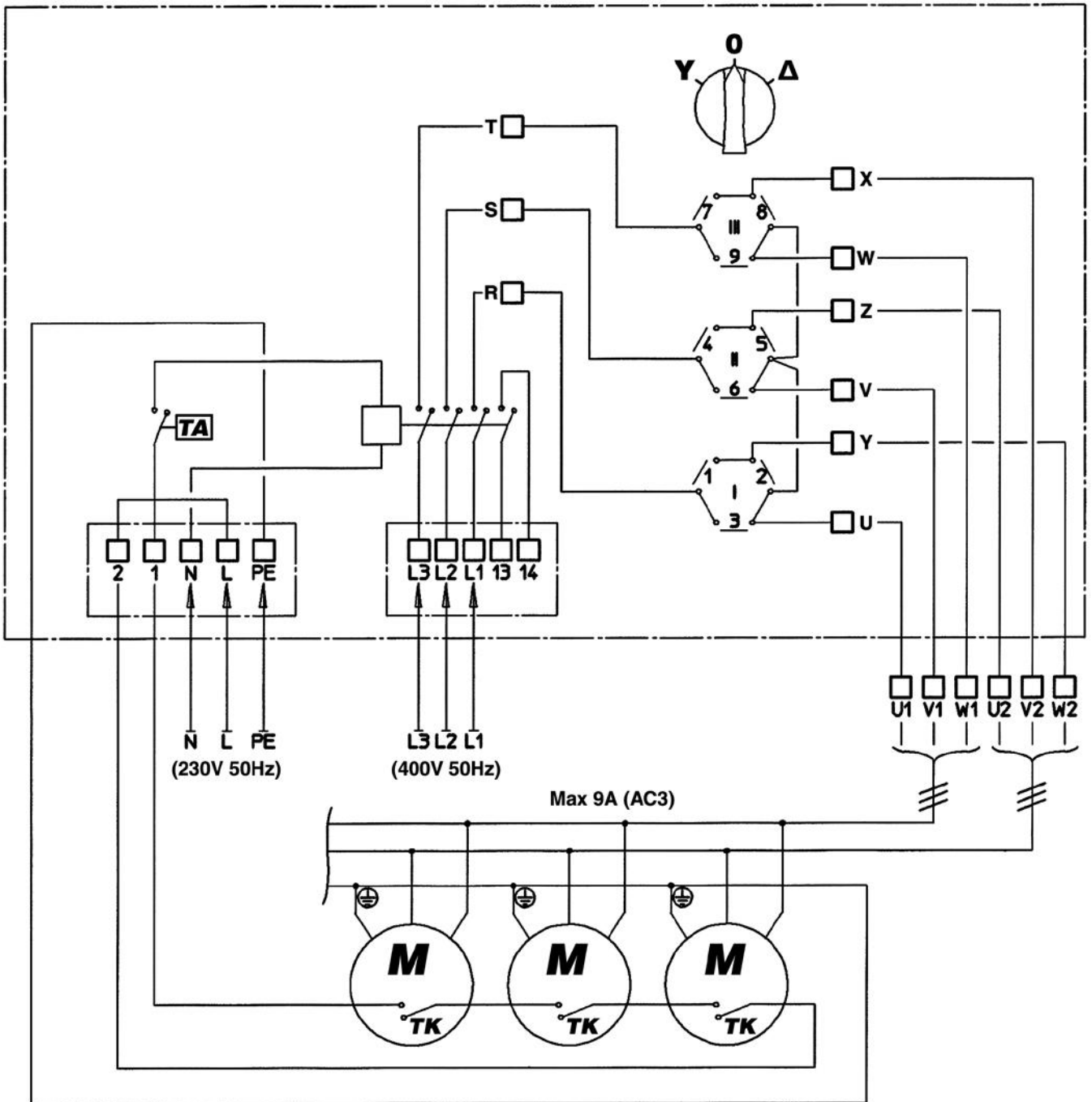

LEGEND:

Y = Low speed **Δ** = High speed **M** = Motor
TA = Room thermostat **TK** = Safety thermostat (Klixon)

**Manual three-position switch with thermostat
for two speed Delta-Star motors, 6/8 poles, three phase, 400 V,
with Klixon thermic protection**

IDENTIFICATION	CODE
BS 3-ST	9007656

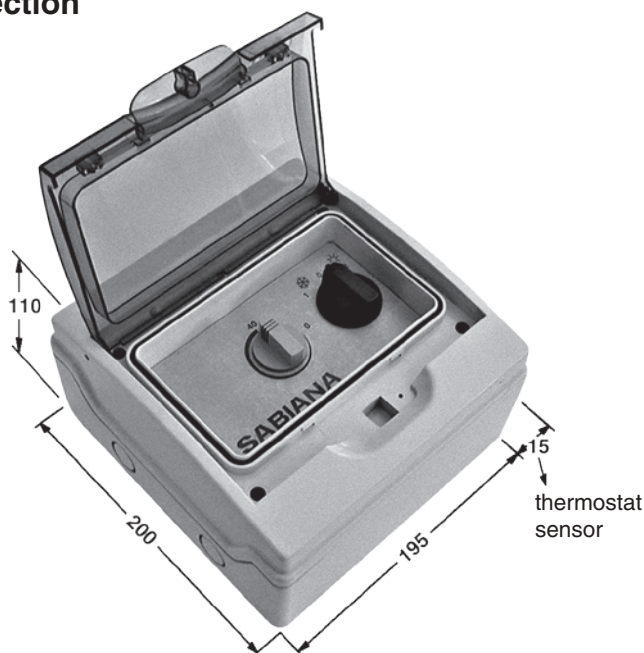

IMPORTANT

**THIS DEVICE IS NOT SUITABLE
FOR EX AMBIENT OR FOR THE CONTROL OF SINGLE-PHASE MOTORS.**

Description

Wall mounted plastic case, containing:

- 1 manual switch for manually selecting the unit heater fan speed as follows:
in Summer 1 speed selection, low speed only (0-1) – in Winter 2 speed selections (0-1-2);
- 1 four pole control contactor;
- 1 voltage-free auxiliary contact used to control or lockout of external appliances;
- 1 room thermostat;
- Terminal block for the connection of the unit heaters, motor overload devices and external thermostat.

Technical specifications

- Wall control.
- Index of protection IP 40.
- Operating voltage 3 x 400V 50Hz.
- Control voltage 1 x 230V.
- Rated operating current 9A 400V (AC3).

Applications

Switch for controlling the fan speed on one or more Sabiana unit heaters, with built-in temperature control. Depending on the set room temperature, the control stops or starts the unit heaters at the speed selected on the speed switch. The bulb of the thermostat is positioned outside of the panel casing.

Motor thermal overload devices

The Sabiana unit heater motors are fitted with internal TK thermal overload devices. The thermal overload device must be connected to the control panel, so that the latter automatically cuts off power to the unit heater if the overload is activated. If the control panel is connected to a series of unit heaters, the TK overload devices on each motor must be connected together in series, and then connected to the corresponding terminals on the control panel.

Installation

Check that the position chosen for the installation of the panel does not affect the correct operation of the room thermostat. Avoid fastening the control panel to cold walls, in areas affected by cold/hot air currents or at an unusual height.

Electric connection

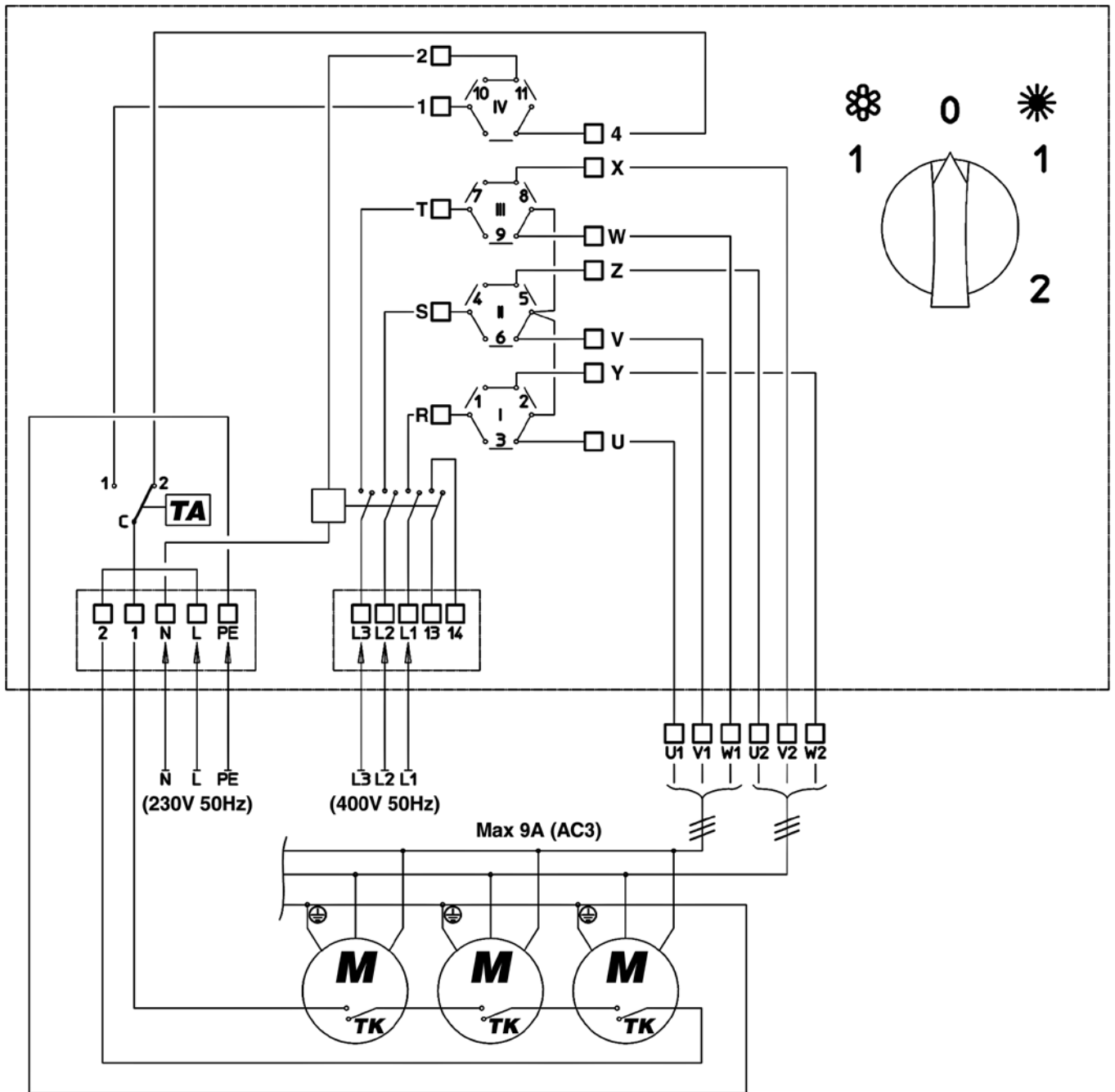

LEGEND:

- Y** = Low speed **Δ** = High speed **M** = Motor
TA = Room thermostat **TK** = Safety thermostat (Klixon)

Heating / Air Conditioning
Comfort Circular Unit Heater
Polaris Air Conditioner



SABIANA
IL CLIMA AMICO

A leading brand of  **AFG**

Sabiana s.p.a. • via Piave, 53 • 20011 Corbetta • Milano • Italy • phone +39.02.97203.1 r.a. / +39.02.97270429 / +39.02.97270576
fax +39.02.9777282 / +39.02.9772820 • www.sabiana.it • info@sabiana.it

CP - EX - 07/15
Cod. A4030100 C/07/15