



Cert. n° 0545

Compliant
with
ERP 2015 Regulation (EU)
No. 327/2011



Heating / Air Conditioning
Atlas and Helios Unit Heaters
Janus 05 Air Conditioners
AIX Stainless Steel Unit Heaters
Atlas STP Door Curtains
Jetstream Induction Flow Optimizers



SABIANA
IL CLIMA AMICO

A leading brand of  **AFG**



IL CLIMA AMICO



CONTENTS

• Introduction	Page 3
• Atlas/Helios version	Page 4
- Construction features	Page 5
- Operation limits	Page 5
• Atlas version	Page 6
- Identification code	Page 6
- Dimensions, Weight, Water content	Page 6
• Helios version	Page 7
- Identification code	Page 7
- Dimensions, Weight, Water content	Page 7
• Atlas/Helios version	Page 8
- Technical characteristics	Page 20
- Coil pressure drop	Page 20
• Janus 05 version	Page 22
- Construction features	Page 22
- Operation limits	Page 22
- Identification code	Page 23
- Dimensions, Weight, Water content	Page 23
- Heating emission	Page 24
- Cooling emission	Page 25
- Water side pressure drop	Page 25
• AIX version	Page 26
- Construction features	Page 26
- Operation limits	Page 26
- Identification code	Page 27
- Dimensions, Weight, Water content	Page 27
- Heating emission	Page 28
- Water side pressure drop	Page 29
• JETSTREAM version	Page 30
- Construction features	Page 31
- Available versions	Page 31
- Dimensions and Weight	Page 31
- Mounting heights and air throw	Page 32
• Atlas STP version	Page 33
- Construction features	Page 33
- Dimensions, Weight, Water content	Page 33
- Correct selection of the door curtain	Page 34
- Technical characteristics	Page 34
• ON-OFF valves	Page 35
• Accessories and Air boxes	Page 36
• Motors	Page 42
• Controls	Page 46
• Hydraulic connections	Page 54



Introduction

Since 1950 Sabiana has been manufacturing hot water, high temperature hot water and steam unit heaters for heating industrial and commercial environments, with proprietary manufacturing technology and a wide range of solutions.

In all the European countries the most common heating system for industrial environments uses hot water unit heaters connected to a central heating system. The excellent ratio of indoor comfort to system cost, continual improvements in efficiency of hot water production, using both condensing boilers and heat pumps, the use of specific solutions such as flow optimisers on the units, as well as flexible installation and easy adaptation to new production plant layouts even after installation, mean that still today thousands of designers and businesses propose and adopt this heating solution.



Following increased demand for low-cost cooling in summer, a new generation of units fitted with coils designed for use with cold water, has joined the traditional series of hot water unit heaters, with the result that a complete range of solutions can now be offered to meet all needs.

All range is compliant with the new ERP 2015 Regulation (EU) No. 327/2011 which requires very low electric consumption ratings in relation to performances provided.

Sabiana is the leading manufacturer of unit heaters, and competes worldwide providing the latest technology in environmental comfort.



Coil

- The coil of Sabiana **Atlas** and **Helios** unit heaters with steel tubes Ø 22 mm and aluminium fins has the following advantages compared with the copper-aluminium small diameter tube coils: the material used for the steel tube, which is very thick (1 mm instead of 0,3 - 0,4 mm), makes the Sabiana coil extremely sturdy and long lasting.
- The tube's large diameter reduces the water pressure drop: this means that reduced power pumps are installed and a very rapid heating capacity is provided.
- The Sabiana coil for unit heaters uses a reduced number of tubes to give the same output: this gives a low resistance to the air flow and consequently an optimum leaving air temperature and a very long throw.
- With a greater spacing between the fins as well as their thickness this facilitates cleaning and maintenance operations, which is essential to keep the unit heater efficient.
The steel tube coil is the ideal choice for installations where all tubes and equipment are made of steel because it avoids physical and chemical unbalance due to the interaction of different metals.
- The special paint coating makes the coil long lasting and increases the thermal output.
- The Sabiana coil can be used with hot water, high temperature hot water or steam, even with a high working pressure. Each coil is submitted to two tests at 30 bars.
- However, in order to meet any design or installation needs Sabiana can offer a complete set of unit heaters with copper tubes and aluminium fins. This coil has the same features (tube diameter, fin pitch, etc.) of the steel coil but it is built with copper tube 0,7 mm thick of higher quality and with a higher mass than the coils normally used for unit heaters.
- The wide range of products consists of **10 different sizes** with **1, 2 or 3 rows** each.

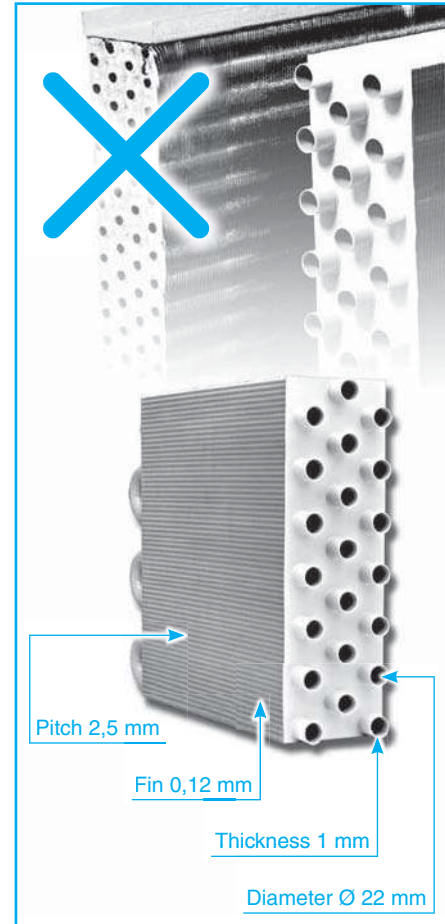

Electric motor

Asynchronous three phase 3Ph-400V-50Hz.

Construction of closed type, with aluminum alloy casing, self-lubricating sealed ball bearings, IP 55 protection, class B insulation.

- Two speed 1350-1000 r.p.m. (from size 1 to size 6) or 900-700 r.p.m. for all sizes with klixon thermic protection.
- On request, one speed 4 poles (1400 r.p.m.) or 6 poles (900 r.p.m.), IP44 protection, for sizes 1 to 6 only.
- On request single phase supply with capacitor supplied separately, for sizes 1 to 6 only.
-  II 2 G IIB T4/T3 flameproof motors are also available (for all sizes, one speed only; not for Helios).

Helicoidal fan

The fan is of the helicoidal design with aluminium blades statically and dynamically balanced.

Its rational high capacity profile provides the highest air flow with minimum noise level and electrical consumption.

The air flow is uniformly distributed through the whole coil and consequently the unit is very quiet.

Electric fan support

The finger proof guard also acts as the main support and fixing frame.

This frame, made from galvanized steel, is mounted onto the main casing via residually anti-vibration rubber mountings.

Casing

Atlas version: the main casing is manufactured from galvanized prepainted steel finished in a light grey colour (RAL 9002) and is assembled from three component parts.

The steel is 1 mm thick and prepainted before manufacture to prevent the material being subjected to oxidation. The use of steel with 200 gr/m². (according to Euronorm 142-79) and prepainting guarantees a perfect finish and superior protection against corrosion.

The component parts are held together by anti vibration screws that allow easy and fast access and maintenance of the unit and coil.



Helios version: with the casing manufactured of anodized aluminium, the elegance of this unit allows it to fit in environments with high aesthetic requirements, such as exhibition halls, supermarkets and conference rooms.

In all cases, **Helios** adds an elegant technical touch to the environment it is installed in.

Even its deflectors are made of extruded aluminium and have a particularly efficient wing profile.



Louvres

Louvres are made from a profiled prepainted steel sheet for the **Atlas version** or extruded aluminium for the **Helios version**, with a design that allows excellent direction of air flow.

The adjustable louvres are held in place by spring loaded pivots which allow the rotation of every single louvre in the desired position without vibrations.

Fourway distribution is achieved by the addition of a second set of louvres to the front of the unit, generally for downward application.

Atlas/Helios version – Operation limits

WATER Maximum water temperature = max. 170°C

Maximum working pressure = 1600 kPa (16 bars)

STEAM Maximum working pressure = 1000 kPa (10 bars)
For steam we recommend the use of copper tube coils.

Reference: 46A42

46	A	4	2	SX
MOTOR 4/6 POLE (1350/1000 r.p.m.)	RANGE ATLAS	SIZE 4	ROWS 2	COIL STEEL TUBE

SP
COIL COPPER TUBE

Atlas version – Dimensions, Weight, Water content

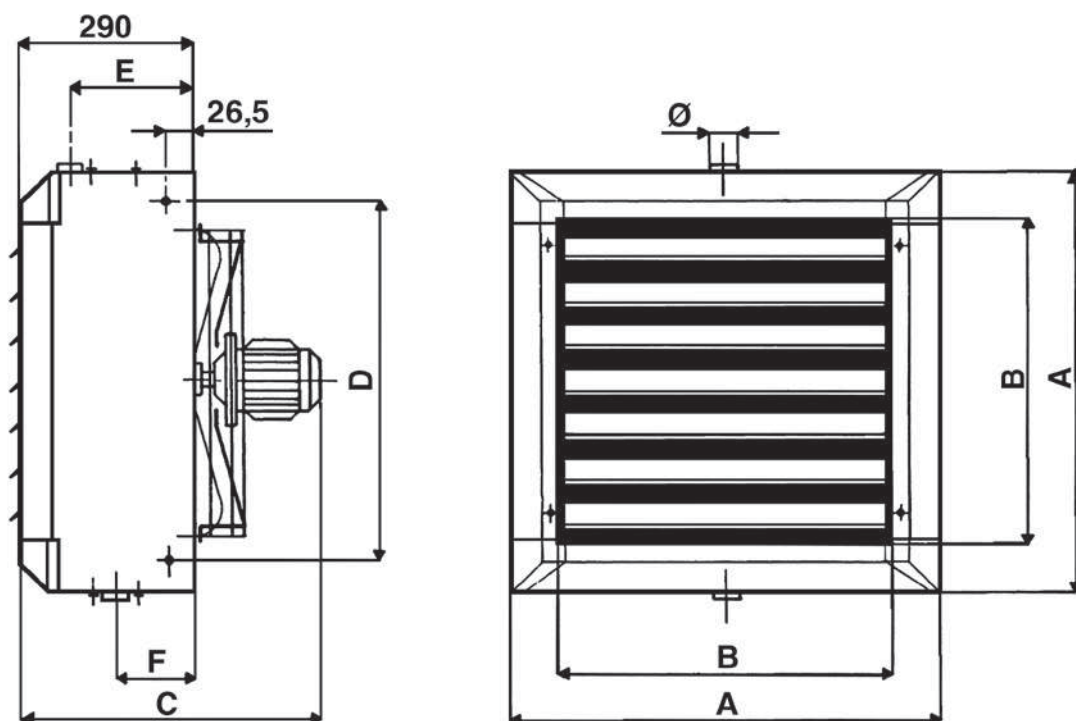

SIZE	Dimensions (mm)								Weight (kg)						Water content (liters)		
	A	B	C	(ATEX)	D	E	F	Ø	1R	(ATEX)	2R	(ATEX)	3R	(ATEX)	1R	2R	3R
1	472	336	465	(595)	375	220	130	1 1/4"	19	(32)	22	(35)	24	(37)	1,3	2,6	3,9
2	526	390	465	(595)	429	220	130	1 1/4"	22	(35)	25	(37)	27	(40)	1,6	3,2	4,8
3	580	444	465	(595)	483	220	130	1 1/4"	26	(38)	30	(42)	33	(45)	1,9	3,8	5,7
4	634	498	488	(618)	537	220	130	1 1/4"	30	(42)	34	(46)	38	(50)	2,3	4,6	6,9
5	688	552	488	(618)	591	220	130	1 1/4"	33	(47)	40	(54)	44	(58)	3,0	6,0	9,0
6	742	606	513	(643)	645	220	130	1 1/4"	38	(52)	46	(60)	51	(65)	3,5	7,0	10,5
7	793	657	560	(740)	696	210	140	1 1/2"	46	(63)	55	(72)	61	(78)	4,3	8,2	12,3
8	900	764	575	(755)	803	210	140	1 1/2"	55	(71)	66	(82)	73	(89)	5,8	11,1	16,6
9	1010	874	595	(775)	913	210	140	1 1/2"	65	(86)	79	(100)	88	(109)	7,6	14,5	21,8
10	1117	980	640	(820)	1020	210	140	2"	79	(98)	95	(114)	106	(125)	9,6	18,2	27,3

Reference: 46H53

46	H	5	3	SX
MOTOR 4/6 POLE (1350/1000 r.p.m.)	RANGE HELIOS	SIZE 5	ROWS 3	COIL STEEL TUBE

SP
COIL COPPER TUBE

Helios version – Dimensions, Weight, Water content

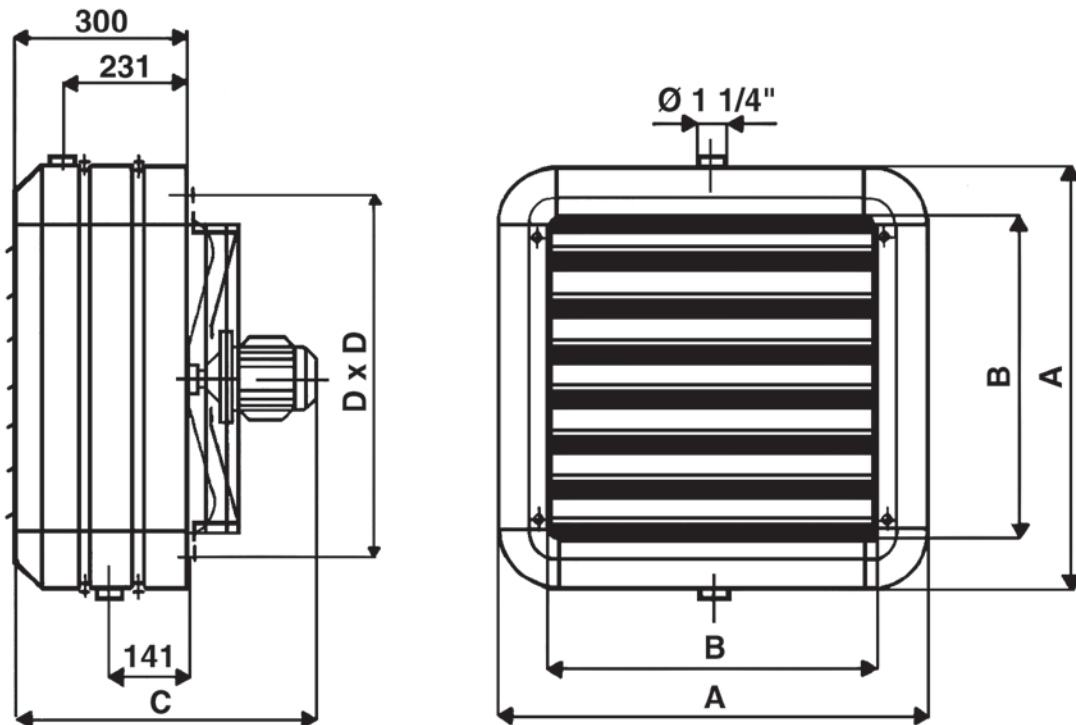

SIZE	Dimensions (mm)				Weight (kg)			Water content (liters)		
	A	B	C	D	1R	2R	3R	1R	2R	3R
1	486	330	477	406	19	22	24	1,3	2,6	3,9
2	540	384	477	460	22	25	27	1,6	3,2	4,8
3	594	438	477	514	26	30	33	1,9	3,8	5,7
4	648	492	500	568	30	34	38	2,3	4,6	6,9
5	702	546	500	622	33	40	44	3,0	6,0	9,0
6	756	600	525	676	38	46	51	3,5	7,0	10,5

4/6 Pole models – WATER Temperature 85-75°C

Drop 10°C – Δtm 65°C – Entering air temperature 15°C

SIZE	MOTOR SPEED		MODEL		AIR FLOW		NOISE LEVEL AT 5 m (★)		EMISSION		LEAVING AIR TEMPERATURE		POLES	Mounting heights:				
	r.p.m.		Atlas	Helios	m³/h		dB(A)		kW		°C			Horizontal discharge		Vertical discharge		
	4 POLES	6 POLES			4 POLES	6 POLES	4 POLES	6 POLES	4 POLES	6 POLES	4 POLES	6 POLES		HEIGHT m	THROW m	HEIGHT max. m	COVER m²	
1	1350	1000	46A11	46H11	1415	1055	56	50	-	-	-	-	4	2,5÷3,5	7,5	3,5	50	
			46A12	46H12	1340	990	56	50	10,24	8,79	37,4	41,0		6	2,5÷3	5	3	36
			46A13	46H13	1195	885	56	50	11,39	9,62	42,9	46,8						
2	1350	1000	46A21	46H21	2190	1680	59	53	-	-	-	-	4	3÷4	10	4	60	
			46A22	46H22	2010	1570	59	53	13,95	12,36	35,3	38,0		6	2,5÷3,5	7	3,5	45
			46A23	46H23	1875	1420	59	53	17,52	15,07	42,4	46,0						
3	1350	1000	46A31	46H31	3325	2510	61	55	-	-	-	-	4	3÷4	13,5	5	70	
			46A32	46H32	2915	2255	61	55	20,85	18,44	35,9	38,9		6	2,5÷3,5	10	4	50
			46A33	46H33	2610	2040	61	55	25,68	22,41	43,8	47,1						
4	1350	1000	46A41	46H41	4415	3305	64	57	-	-	-	-	4	3,5÷4,5	16	5,5	75	
			46A42	46H42	3725	2745	64	57	27,86	24,06	36,9	40,6		6	3÷4	12	4,5	55
			46A43	46H43	3210	2390	64	57	32,03	27,14	44,2	48,2						
5	1350	1000	46A51	46H51	5770	4250	66	59	-	-	-	-	4	4÷5	18	6	90	
			46A52	46H52	4800	3500	66	59	34,89	29,94	36,3	40,0		6	3,5÷4,5	13	5	70
			46A53	46H53	4325	3110	66	59	43,06	35,90	44,1	48,8						
6	1350	1000	46A61	46H61	6590	5065	69	62	-	-	-	-	4	4÷5,5	22	7	120	
			46A62	46H62	5515	4160	69	62	41,76	36,36	37,2	40,6		6	4÷5	16	6	100
			46A63	46H63	4900	3620	69	62	50,96	42,98	45,4	49,7						

(★) = The sound pressure levels dB(A) are measured at a distance of 5m, directional factor Q=2, compliant with the EN 3744 standard.

Correction factors

Water temperature °C

Entering air temperature	50/40	55/45	60/50	65/55	70/60	75/65	80/70	85/75	90/80
-10	0,85	0,92	1,00	1,08	1,15	1,23	1,31	1,38	1,46
-5	0,77	0,85	0,92	1,00	1,08	1,15	1,23	1,31	1,38
0	0,69	0,77	0,85	0,92	1,00	1,08	1,15	1,23	1,31
+5	0,62	0,69	0,77	0,85	0,92	1,00	1,08	1,15	1,23
+10	0,54	0,62	0,69	0,77	0,85	0,92	1,00	1,08	1,15
+15	0,46	0,54	0,62	0,69	0,77	0,85	0,92	1,00	1,08
+20	0,39	0,46	0,54	0,62	0,69	0,77	0,85	0,92	1,00
+25	0,31	0,39	0,46	0,54	0,62	0,69	0,77	0,85	0,92

Mounting heights

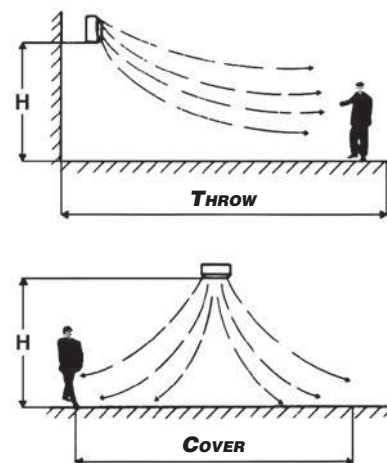

6/8 Pole models – WATER Temperature 85-75°C

Drop 10°C – Δtm 65°C – Entering air temperature 15°C

SIZE	MOTOR SPEED		MODEL		AIR FLOW		NOISE LEVEL AT 5 m (*)		EMISSION		LEAVING AIR TEMPERATURE		POLES	Mounting heights:				
	r.p.m.				m³/h		dB(A)		kW		°C			Horizontal discharge		Vertical discharge		
	6 POLES	8 POLES	Atlas	Helios	6 POLES	8 POLES	6 POLES	8 POLES	6 POLES	8 POLES	6 POLES	8 POLES		HEIGHT m	THROW m	HEIGHT max. m	COVER m²	
1	900	750	68A11	68H11	970	860	48	44	-	-	-	-	6	2,5÷3	5	3	36	
			68A12	68H12	935	830	48	44	8,54	8,01	41,7	43,2		8	2,5÷3	4,5	-	-
			68A13	68H13	835	740	48	44	9,29	8,65	47,5	49,2						
2	900	750	68A21	68H21	1495	1170	50	46	-	-	-	-	6	2,5÷3,5	7	3,5	45	
			68A22	68H22	1410	1100	50	46	11,70	10,26	39,3	42,3		8	2,5÷3,5	5,5	-	-
			68A23	68H23	1290	1025	50	46	14,23	12,41	47,3	50,4						
3	900	750	68A31	68H31	2100	1620	52	48	-	-	-	-	6	2,5÷3,5	10	4	50	
			68A32	68H32	1880	1470	52	48	16,83	14,74	41,2	44,3		8	2,5÷3,5	7	-	-
			68A33	68H33	1735	1320	52	48	20,39	17,28	49,4	53,3						
4	900	750	68A41	68H41	2795	2195	54	50	-	-	-	-	6	3÷4	12	4,5	55	
			68A42	68H42	2345	1755	54	50	22,14	18,91	42,6	46,5		8	3÷4	8	-	-
			68A43	68H43	2010	1535	54	50	24,47	20,70	50,6	54,4						
5	900	750	68A51	68H51	3685	2865	56	51	-	-	-	-	6	3,5÷4,5	13	5	70	
			68A52	68H52	3050	2335	56	51	27,87	24,17	41,7	45,3		8	3,5÷4,5	9,5	-	-
			68A53	68H53	2785	2100	56	51	33,58	27,27	50,3	54,4						
6	900	750	68A61	68H61	4445	3550	59	54	-	-	-	-	6	4÷5	16	6	100	
			68A62	68H62	3710	2960	59	54	34,33	30,37	42,1	45,0		8	4÷5	12	-	-
			68A63	68H63	3270	2610	59	54	40,43	35,19	51,2	54,4						
7	900	750	68A71	-	5100	3960	65	59	-	-	-	-	6	4÷5	24	7	120	
			68A72	-	4800	3650	65	59	44,20	38,13	41,9	45,6		8	3,5÷4	18	6	100
			68A73	-	4600	3500	65	59	52,35	44,50	48,3	52,2						
8	900	750	68A81	-	7650	5400	67	61	-	-	-	-	6	4÷5,5	26	9	160	
			68A82	-	6900	4950	67	61	57,57	48,47	39,4	43,6		8	3,5÷4,5	20	7	130
			68A83	-	6300	4500	67	61	70,23	57,52	47,6	52,4						
9	900	750	68A91	-	10600	7600	68	62	-	-	-	-	6	4÷6	28	11	200	
			68A92	-	10200	7200	68	62	82,12	68,82	38,6	43,0		8	3,5÷5	21	8	150
			68A93	-	9400	6400	68	62	101,49	81,06	46,6	52,1						
10	900	750	68A101	-	12250	9215	71	65	-	-	-	-	6	4÷6	30	12	220	
			68A102	-	11800	8800	71	65	101,20	86,99	40,1	43,9		8	4÷5	22	9	160
			68A103	-	11000	7950	71	65	124,93	102,93	48,2	52,9						

(*) = The sound pressure levels dB(A) are measured at a distance of 5m, directional factor Q=2, compliant with the EN 3744 standard.

Correction factors

Water temperature °C

Entering air temperature	50/40	55/45	60/50	65/55	70/60	75/65	80/70	85/75	90/80
-10	0,85	0,92	1,00	1,08	1,15	1,23	1,31	1,38	1,46
-5	0,77	0,85	0,92	1,00	1,08	1,15	1,23	1,31	1,38
0	0,69	0,77	0,85	0,92	1,00	1,08	1,15	1,23	1,31
+5	0,62	0,69	0,77	0,85	0,92	1,00	1,08	1,15	1,23
+10	0,54	0,62	0,69	0,77	0,85	0,92	1,00	1,08	1,15
+15	0,46	0,54	0,62	0,69	0,77	0,85	0,92	1,00	1,08
+20	0,39	0,46	0,54	0,62	0,69	0,77	0,85	0,92	1,00
+25	0,31	0,39	0,46	0,54	0,62	0,69	0,77	0,85	0,92

Mounting heights

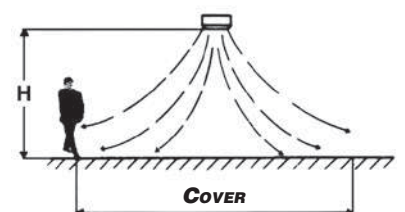
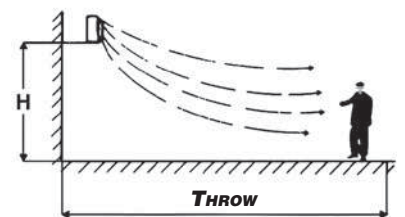

4/6 Pole models – WATER Temperature 85-70°C

Drop 15°C – Δtm 62.5°C – Entering air temperature 15°C

SIZE	MOTOR SPEED		MODEL		AIR FLOW		NOISE LEVEL AT 5 m (★)		EMISSION		LEAVING AIR TEMPERATURE		POLES	Mounting heights:				
	r.p.m.		Atlas	Helios	m³/h		dB(A)		kW		°C			Horizontal discharge		Vertical discharge		
	4 POLES	6 POLES			4 POLES	6 POLES	4 POLES	6 POLES	4 POLES	6 POLES	4 POLES	6 POLES		HEIGHT m	THROW m	HEIGHT max. m	COVER m²	
1	1350	1000	46A11	46H11	1415	1055	56	50	-	-	-	-	4	2,5÷3,5	7,5	3,5	50	
			46A12	46H12	1340	990	56	50	8,77	7,59	34,1	37,4		6	2,5÷3	5	3	36
			46A13	46H13	1195	885	56	50	9,86	8,36	39,1	42,6						
2	1350	1000	46A21	46H21	2190	1680	59	53	-	-	-	-	4	3÷4	10	4	60	
			46A22	46H22	2010	1570	59	53	12,31	10,93	32,9	35,4		6	2,5÷3,5	7	3,5	45
			46A23	46H23	1875	1420	59	53	15,56	13,37	39,3	42,6						
3	1350	1000	46A31	46H31	3325	2510	61	55	-	-	-	-	4	3÷4	13,5	5	70	
			46A32	46H32	2915	2255	61	55	18,70	16,57	33,8	36,5		6	2,5÷3,5	10	4	50
			46A33	46H33	2610	2040	61	55	23,12	20,21	40,9	44,0						
4	1350	1000	46A41	46H41	4415	3305	64	57	-	-	-	-	4	3,5÷4,5	16	5,5	75	
			46A42	46H42	3725	2745	64	57	25,33	21,88	34,9	38,2		6	3÷4	12	4,5	55
			46A43	46H43	3210	2390	64	57	29,18	24,80	41,6	45,4						
5	1350	1000	46A51	46H51	5770	4250	66	59	-	-	-	-	4	4÷5	18	6	90	
			46A52	46H52	4800	3500	66	59	31,91	27,44	34,5	37,9		6	3,5÷4,5	13	5	70
			46A53	46H53	4325	3110	66	59	39,52	33,00	41,7	46,0						
6	1350	1000	46A61	46H61	6590	5065	69	62	-	-	-	-	4	4÷5,5	22	7	120	
			46A62	46H62	5515	4160	69	62	38,54	33,64	35,4	38,7		6	4÷5	16	6	100
			46A63	46H63	4900	3620	69	62	47,18	39,76	43,2	47,1						

(★) = The sound pressure levels dB(A) are measured at a distance of 5m, directional factor Q=2, compliant with the EN 3744 standard.

Correction factors

Water temperature °C

Entering air temperature	50/35	55/40	60/45	65/50	70/55	75/60	80/65	85/70	90/75
-10	0,84	0,92	1,00	1,08	1,16	1,24	1,32	1,40	1,48
-5	0,76	0,84	0,92	1,00	1,08	1,16	1,24	1,32	1,40
0	0,67	0,76	0,84	0,92	1,00	1,08	1,16	1,24	1,32
+5	0,60	0,68	0,76	0,84	0,92	1,00	1,08	1,16	1,24
+10	0,52	0,60	0,68	0,76	0,84	0,92	1,00	1,08	1,16
+15	0,44	0,52	0,60	0,68	0,76	0,84	0,92	1,00	1,08
+20	0,36	0,44	0,52	0,60	0,68	0,76	0,84	0,92	1,00
+25	0,28	0,36	0,44	0,52	0,60	0,68	0,76	0,84	0,92

Mounting heights

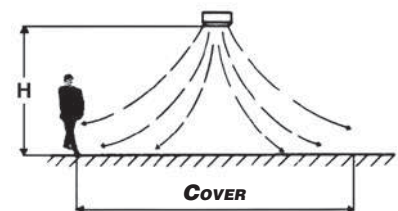
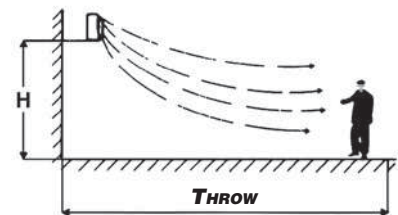

6/8 Pole models – WATER Temperature 85-70°C

Drop 15°C – Δtm 62.5°C – Entering air temperature 15°C

SIZE	MOTOR SPEED		MODEL		AIR FLOW		NOISE LEVEL AT 5 m (*)		EMISSION		LEAVING AIR TEMPERATURE		POLES	Mounting heights:				
	r.p.m.				m³/h		dB(A)		kW		°C			Horizontal discharge		Vertical discharge		
	6 POLES	8 POLES	Atlas	Helios	6 POLES	8 POLES	6 POLES	8 POLES	6 POLES	8 POLES	6 POLES	8 POLES		HEIGHT m	THROW m	HEIGHT max. m	COVER m²	
1	900	750	68A11	68H11	970	860	48	44	-	-	-	-	6	2,5÷3	5	3	36	
			68A12	68H12	935	830	48	44	7,36	6,93	38,0	39,4		8	2,5÷3	4,5	-	-
			68A13	68H13	835	740	48	44	8,08	7,54	43,3	44,8						
2	900	750	68A21	68H21	1495	1170	50	46	-	-	-	-	6	2,5÷3,5	7	3,5	45	
			68A22	68H22	1410	1100	50	46	10,35	9,10	36,5	39,2		8	2,5÷3,5	5,5	-	-
			68A23	68H23	1290	1025	50	46	12,66	11,09	43,7	46,7						
3	900	750	68A31	68H31	2100	1620	52	48	-	-	-	-	6	2,5÷3,5	10	4	50	
			68A32	68H32	1880	1470	52	48	15,11	13,29	38,5	41,5		8	2,5÷3,5	7	-	-
			68A33	68H33	1735	1320	52	48	18,41	15,67	46,0	49,7						
4	900	750	68A41	68H41	2795	2195	54	50	-	-	-	-	6	3÷4	12	4,5	55	
			68A42	68H42	2345	1755	54	50	20,17	17,27	40,2	43,8		8	3÷4	8	-	-
			68A43	68H43	2010	1535	54	50	22,41	18,98	47,6	51,2						
5	900	750	68A51	68H51	3685	2865	56	51	-	-	-	-	6	3,5÷4,5	13	5	70	
			68A52	68H52	3050	2335	56	51	25,59	22,21	39,5	42,8		8	3,5÷4,5	9,5	-	-
			68A53	68H53	2785	2100	56	51	30,98	26,11	47,5	51,4						
6	900	750	68A61	68H61	4445	3550	59	54	-	-	-	-	6	4÷5	16	6	100	
			68A62	68H62	3710	2960	59	54	31,73	28,15	40,0	42,8		8	4÷5	12	-	-
			68A63	68H63	3270	2610	59	54	37,45	32,69	48,5	51,6						
7	900	750	68A71	-	5100	3960	65	59	-	-	-	-	6	4÷5	24	7	120	
			68A72	-	4800	3650	65	59	41,06	35,48	40,0	43,4		8	3,5÷4	18	6	100
			68A73	-	4600	3500	65	59	48,70	41,47	46,0	49,7						
8	900	750	68A81	-	7650	5400	67	61	-	-	-	-	6	4÷5,5	26	9	160	
			68A82	-	6900	4950	67	61	52,57	44,42	37,3	41,3		8	3,5÷4,5	20	7	130
			68A83	-	6300	4500	67	61	64,34	52,79	44,9	49,3						
9	900	750	68A91	-	10600	7600	68	62	-	-	-	-	6	4÷6	28	11	200	
			68A92	-	10200	7200	68	62	75,80	63,60	36,7	40,8		8	3,5÷5	21	8	150
			68A93	-	9400	6400	68	62	93,80	75,08	44,2	49,3						
10	900	750	68A101	-	12250	9215	71	65	-	-	-	-	6	4÷6	30	12	220	
			68A102	-	11800	8800	71	65	94,03	80,82	38,3	41,9		8	4÷5	22	9	160
			68A103	-	11000	7950	71	65	116,19	96,05	45,9	50,3						

(*) = The sound pressure levels dB(A) are measured at a distance of 5m, directional factor Q=2, compliant with the EN 3744 standard.

Correction factors

Water temperature °C

Entering air temperature	50/35	55/40	60/45	65/50	70/55	75/60	80/65	85/70	90/75
-10	0,84	0,92	1,00	1,08	1,16	1,24	1,32	1,40	1,48
-5	0,76	0,84	0,92	1,00	1,08	1,16	1,24	1,32	1,40
0	0,67	0,76	0,84	0,92	1,00	1,08	1,16	1,24	1,32
+5	0,60	0,68	0,76	0,84	0,92	1,00	1,08	1,16	1,24
+10	0,52	0,60	0,68	0,76	0,84	0,92	1,00	1,08	1,16
+15	0,44	0,52	0,60	0,68	0,76	0,84	0,92	1,00	1,08
+20	0,36	0,44	0,52	0,60	0,68	0,76	0,84	0,92	1,00
+25	0,28	0,36	0,44	0,52	0,60	0,68	0,76	0,84	0,92

Mounting heights

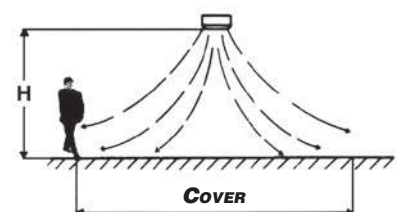
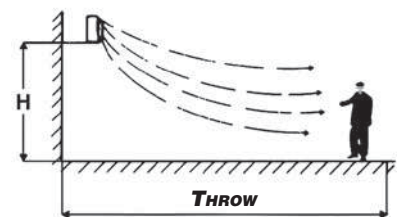

4/6 Pole models – WATER Temperature 90-70°C

Drop 20°C – Δtm 65°C – Entering air temperature 15°C

SIZE	MOTOR SPEED		MODEL		AIR FLOW		NOISE LEVEL AT 5 m (*)		EMISSION		LEAVING AIR TEMPERATURE		POLES	Mounting heights:				
	r.p.m.		Atlas	Helios	m³/h		dB(A)		kW		°C			Horizontal discharge		Vertical discharge		
	4 POLES	6 POLES			4 POLES	6 POLES	4 POLES	6 POLES	4 POLES	6 POLES	4 POLES	6 POLES		HEIGHT m	THROW m	HEIGHT max. m	COVER m²	
1	1350	1000	46A11	46H11	1415	1055	56	50	-	-	-	-	4	2,5÷3,5	7,5	3,5	50	
			46A12	46H12	1340	990	56	50	8,42	7,31	33,4	36,6		6	2,5÷3	5	3	36
			46A13	46H13	1195	885	56	50	9,52	8,11	38,3	41,8			2,5÷3,5	10	4	60
2	1350	1000	46A21	46H21	2190	1680	59	53	-	-	-	-	4	3÷4	10	4	60	
			46A22	46H22	2010	1570	59	53	12,05	10,73	32,5	35,0		6	2,5÷3,5	7	3,5	45
			46A23	46H23	1875	1420	59	53	15,31	13,19	38,9	42,2			3÷4	13,5	5	70
3	1350	1000	46A31	46H31	3325	2510	61	55	-	-	-	-	4	3÷4	13,5	5	70	
			46A32	46H32	2915	2255	61	55	18,54	16,43	33,6	36,3		6	2,5÷3,5	10	4	50
			46A33	46H33	2610	2040	61	55	22,94	20,13	40,7	43,9			3,5÷4,5	16	5,5	75
4	1350	1000	46A41	46H41	4415	3305	64	57	-	-	-	-	4	3,5÷4,5	16	5,5	75	
			46A42	46H42	3725	2745	64	57	25,28	21,86	34,9	38,3		6	3÷4	12	4,5	55
			46A43	46H43	3210	2390	64	57	29,26	24,89	41,7	45,5			4÷5	18	6	90
5	1350	1000	46A51	46H51	5770	4250	66	59	-	-	-	-	4	4÷5	18	6	90	
			46A52	46H52	4800	3500	66	59	32,09	27,61	34,6	38,1		6	3,5÷4,5	13	5	70
			46A53	46H53	4325	3110	66	59	39,85	33,33	42,0	46,4			4÷5,5	22	7	120
6	1350	1000	46A61	46H61	6590	5065	69	62	-	-	-	-	4	4÷5,5	22	7	120	
			46A62	46H62	5515	4160	69	62	38,94	34,01	35,7	38,9		6	4÷5	16	6	100
			46A63	46H63	4900	3620	69	62	47,73	40,34	43,5	47,6						

(*) = The sound pressure levels dB(A) are measured at a distance of 5m, directional factor Q=2, compliant with the EN 3744 standard.

Correction factors

Water temperature °C

Entering air temperature	60/40	70/50	80/60	85/65	90/70	95/75
-10	0,92	1,08	1,23	1,31	1,38	1,46
-5	0,85	1,00	1,15	1,23	1,31	1,38
0	0,77	0,92	1,08	1,15	1,23	1,31
+5	0,69	0,85	1,00	1,08	1,15	1,23
+10	0,62	0,77	0,92	1,00	1,08	1,15
+15	0,54	0,69	0,85	0,92	1,00	1,08
+20	0,46	0,62	0,77	0,85	0,92	1,00
+25	0,38	0,54	0,69	0,77	0,85	0,92

Mounting heights

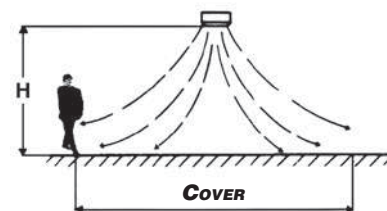
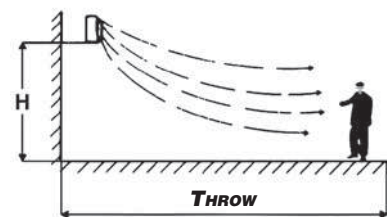

6/8 Pole models – WATER Temperature 90-70°C

Drop 20°C – Δtm 65°C – Entering air temperature 15°C

SIZE	MOTOR SPEED		MODEL		AIR FLOW		NOISE LEVEL AT 5 m (*)		EMISSION		LEAVING AIR TEMPERATURE		POLES	Mounting heights:				
	r.p.m.				m³/h		dB(A)		kW		°C			Horizontal discharge		Vertical discharge		
	6 POLES	8 POLES	Atlas	Helios	6 POLES	8 POLES	6 POLES	8 POLES	6 POLES	8 POLES	6 POLES	8 POLES		HEIGHT m	THROW m	HEIGHT max. m	COVER m²	
1	900	750	68A11	68H11	970	860	48	44	-	-	-	-	6	2,5÷3	5	3	36	
			68A12	68H12	935	830	48	44	7,12	6,69	37,3	35,6		8	2,5÷3	4,5	-	-
			68A13	68H13	835	740	48	44	7,86	7,34	42,5	44,0						
2	900	750	68A21	68H21	1495	1170	50	46	-	-	-	-	6	2,5÷3,5	7	3,5	45	
			68A22	68H22	1410	1100	50	46	10,17	8,98	36,1	38,9		8	2,5÷3,5	5,5	-	-
			68A23	68H23	1290	1025	50	46	12,50	10,96	43,3	46,3						
3	900	750	68A31	68H31	2100	1620	52	48	-	-	-	-	6	2,5÷3,5	10	4	50	
			68A32	68H32	1880	1470	52	48	15,02	13,25	38,4	41,4		8	2,5÷3,5	7	-	-
			68A33	68H33	1735	1320	52	48	18,38	15,63	46,0	49,6						
4	900	750	68A41	68H41	2795	2195	54	50	-	-	-	-	6	3÷4	12	4,5	55	
			68A42	68H42	2345	1755	54	50	20,20	17,31	40,2	43,9		8	3÷4	8	-	-
			68A43	68H43	2010	1535	54	50	22,50	19,10	47,7	51,4						
5	900	750	68A51	68H51	3685	2865	56	51	-	-	-	-	6	3,5÷4,5	13	5	70	
			68A52	68H52	3050	2335	56	51	25,81	22,39	39,8	43,1		8	3,5÷4,5	9,5	-	-
			68A53	68H53	2785	2100	56	51	31,24	26,40	47,8	51,8						
6	900	750	68A61	68H61	4445	3550	59	54	-	-	-	-	6	4÷5	16	6	100	
			68A62	68H62	3710	2960	59	54	32,05	28,46	40,3	43,1		8	4÷5	12	-	-
			68A63	68H63	3270	2610	59	54	37,99	33,13	49,0	52,1						
7	900	750	68A71	-	5100	3960	65	59	-	-	-	-	6	4÷5	24	7	120	
			68A72	-	4800	3650	65	59	41,64	36,01	40,4	43,9		8	3,5÷4	18	6	100
			68A73	-	4600	3500	65	59	49,53	42,15	46,5	50,2						
8	900	750	68A81	-	7650	5400	67	61	-	-	-	-	6	4÷5,5	26	9	160	
			68A82	-	6900	4950	67	61	52,78	44,62	37,4	41,4		8	3,5÷4,5	20	7	130
			68A83	-	6300	4500	67	61	64,68	53,18	45,0	49,6						
9	900	750	68A91	-	10600	7600	68	62	-	-	-	-	6	4÷6	28	11	200	
			68A92	-	10200	7200	68	62	76,62	64,36	37,0	41,2		8	3,5÷5	21	8	150
			68A93	-	9400	6400	68	62	94,85	76,12	44,5	49,8						
10	900	750	68A101	-	12250	9215	71	65	-	-	-	-	6	4÷6	30	12	220	
			68A102	-	11800	8800	71	65	95,43	82,19	38,7	42,3		8	4÷5	22	9	160
			68A103	-	11000	7950	71	65	118,16	97,74	46,4	51,0						

(*) = The sound pressure levels dB(A) are measured at a distance of 5m, directional factor Q=2, compliant with the EN 3744 standard.

Correction factors

Water temperature °C

Entering air temperature	60/40	70/50	80/60	85/65	90/70	95/75
-10	0,92	1,08	1,23	1,31	1,38	1,46
-5	0,85	1,00	1,15	1,23	1,31	1,38
0	0,77	0,92	1,08	1,15	1,23	1,31
+5	0,69	0,85	1,00	1,08	1,15	1,23
+10	0,62	0,77	0,92	1,00	1,08	1,15
+15	0,54	0,69	0,85	0,92	1,00	1,08
+20	0,46	0,62	0,77	0,85	0,92	1,00
+25	0,38	0,54	0,69	0,77	0,85	0,92

Mounting heights

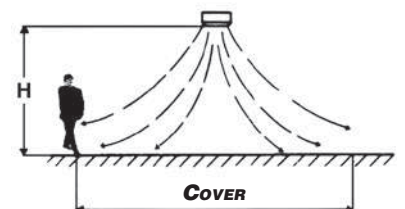
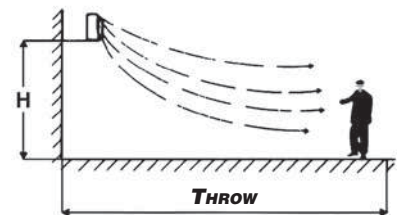

4/6 Pole models – WATER Temperature 130-100°C

Drop 30°C – Δtm 100°C – Entering air temperature 15°C

SIZE	MOTOR SPEED		MODEL		AIR FLOW		NOISE LEVEL AT 5 m (★)		EMISSION		LEAVING AIR TEMPERATURE		POLES	Mounting heights:			
	r.p.m.		Atlas	Helios	m³/h		dB(A)		kW		°C			Horizontal discharge		Vertical discharge	
	4 POLES	6 POLES			4 POLES	6 POLES	4 POLES	6 POLES	4 POLES	6 POLES	4 POLES	6 POLES		HEIGHT m	THROW m	HEIGHT max. m	COVER m²
1	1350	1000	46A11	46H11	1415	1055	56	50	8,23	7,29	32,0	35,2	4	2,5÷3,5	7,5	3,5	50
			46A12	46H12	1340	990	56	50	14,25	12,32	46,1	51,4	6	2,5÷3	5	3	36
			46A13	46H13	1195	885	56	50	-	-	-	-					
2	1350	1000	46A21	46H21	2190	1680	59	53	12,74	11,42	32,0	34,9	4	3÷4	10	4	60
			46A22	46H22	2010	1570	59	53	19,87	17,66	43,9	47,9	6	2,5÷3,5	7	3,5	45
			46A23	46H23	1875	1420	59	53	-	-	-	-					
3	1350	1000	46A31	46H31	3325	2510	61	55	18,70	16,67	31,5	34,4	4	3÷4	13,5	5	70
			46A32	46H32	2915	2255	61	55	30,16	26,71	45,3	49,7	6	2,5÷3,5	10	4	50
			46A33	46H33	2610	2040	61	55	-	-	-	-					
4	1350	1000	46A41	46H41	4415	3305	64	57	24,96	22,21	31,5	34,7	4	3,5÷4,5	16	5,5	75
			46A42	46H42	3725	2745	64	57	40,76	35,20	47,0	52,5	6	3÷4	12	4,5	55
			46A43	46H43	3210	2390	64	57	-	-	-	-					
5	1350	1000	46A51	46H51	5770	4250	66	59	32,45	28,72	31,5	34,8	4	4÷5	18	6	90
			46A52	46H52	4800	3500	66	59	51,23	44,08	46,2	51,8	6	3,5÷4,5	13	5	70
			46A53	46H53	4325	3110	66	59	-	-	-	-					
6	1350	1000	46A61	46H61	6590	5065	69	62	39,15	35,20	32,4	35,3	4	4÷5,5	22	7	120
			46A62	46H62	5515	4160	69	62	61,83	53,98	47,8	53,0	6	4÷5	16	6	100
			46A63	46H63	4900	3620	69	62	-	-	-	-					

(★) = The sound pressure levels dB(A) are measured at a distance of 5m, directional factor Q=2, compliant with the EN 3744 standard.

Correction factors

Water temperature °C

Entering air temperature	110/80	120/90	130/100	140/110	150/120
-10	1,05	1,15	1,25	1,35	1,45
-5	1,00	1,10	1,20	1,30	1,40
0	0,95	1,05	1,15	1,25	1,35
+5	0,90	1,00	1,10	1,20	1,30
+10	0,85	0,95	1,05	1,15	1,25
+15	0,80	0,90	1,00	1,10	1,20
+20	0,75	0,85	0,95	1,05	1,15
+25	0,70	0,80	0,90	1,00	1,10

Mounting heights

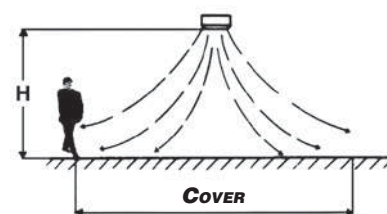
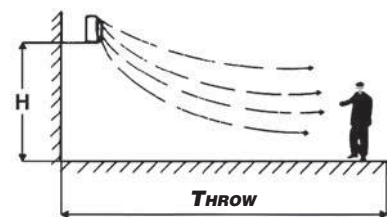

6/8 Pole models – WATER Temperature 130-100°C

Drop 30°C – Δtm 100°C – Entering air temperature 15°C

SIZE	MOTOR SPEED		MODEL		AIR FLOW		NOISE LEVEL AT 5 m (*)		EMISSION		LEAVING AIR TEMPERATURE		POLES	Mounting heights:			
	r.p.m.				m³/h		dB(A)		kW		°C			Horizontal discharge		Vertical discharge	
	6 POLES	8 POLES	Atlas	Helios	6 POLES	8 POLES	6 POLES	8 POLES	6 POLES	8 POLES	6 POLES	8 POLES		HEIGHT m	THROW m	HEIGHT max. m	COVER m²
1	900	750	68A11	68H11	970	860	48	44	7,02	6,67	36,2	37,7	6	2,5÷3	5	3	36
			68A12	68H12	935	830	48	44	11,95	11,25	52,4	54,6		8	2,5÷3	4,5	-
			68A13	68H13	835	740	48	44	-	-	-	-	-		-	-	-
2	900	750	68A21	68H21	1495	1170	50	46	10,88	9,75	36,3	39,4	6	2,5÷3,5	7	3,5	45
			68A22	68H22	1410	1100	50	46	16,73	14,70	49,7	54,1		8	2,5÷3,5	5,5	-
			68A23	68H23	1290	1025	50	46	-	-	-	-	-		-	-	-
3	900	750	68A31	68H31	2100	1620	52	48	15,44	13,75	36,5	39,8	6	2,5÷3,5	10	4	50
			68A32	68H32	1880	1470	52	48	24,40	21,39	53,0	57,6		8	2,5÷3,5	7	-
			68A33	68H33	1735	1320	52	48	-	-	-	-	-		-	-	-
4	900	750	68A41	68H41	2795	2195	54	50	20,66	18,54	36,6	39,7	6	3÷4	12	4,5	55
			68A42	68H42	2345	1755	54	50	32,41	27,76	55,4	61,3		8	3÷4	8	-
			68A43	68H43	2010	1535	54	50	-	-	-	-	-		-	-	-
5	900	750	68A51	68H51	3685	2865	56	51	27,02	24,14	36,5	39,7	6	3,5÷4,5	13	5	70
			68A52	68H52	3050	2335	56	51	41,10	35,68	54,4	59,7		8	3,5÷4,5	9,5	-
			68A53	68H53	2785	2100	56	51	-	-	-	-	-		-	-	-
6	900	750	68A61	68H61	4445	3550	59	54	33,28	30,12	36,9	39,8	6	4÷5	16	6	100
			68A62	68H62	3710	2960	59	54	50,85	45,12	55,1	59,6		8	4÷5	12	-
			68A63	68H63	3270	2610	59	54	-	-	-	-	-		-	-	-
7	900	750	68A71	-	5100	3960	65	59	40,92	36,49	38,5	42,0	6	4÷5	24	7	120
			68A72	-	4800	3650	65	59	65,79	56,89	55,1	60,6		8	3,5÷4	18	6
			68A73	-	4600	3500	65	59	-	-	-	-	-		-	-	-
8	900	750	68A81	-	7650	5400	67	61	52,87	45,40	35,2	39,6	6	4÷5,5	26	9	160
			68A82	-	6900	4950	67	61	84,51	71,27	50,8	57,1		8	3,5÷4,5	20	7
			68A83	-	6300	4500	67	61	-	-	-	-	-		-	-	-
9	900	750	68A91	-	10600	7600	68	62	73,46	63,61	35,3	39,5	6	4÷6	28	11	200
			68A92	-	10200	7200	68	62	121,59	102,00	49,9	56,4		8	3,5÷5	21	8
			68A93	-	9400	6400	68	62	-	-	-	-	-		-	-	-
10	900	750	68A101	-	12250	9215	71	65	91,95	81,02	37,0	40,7	6	4÷6	30	12	220
			68A102	-	11800	8800	71	65	150,86	129,74	52,4	58,1		8	4÷5	22	9
			68A103	-	11000	7950	71	65	-	-	-	-	-		-	-	-

(*) = The sound pressure levels dB(A) are measured at a distance of 5m, directional factor Q=2, compliant with the EN 3744 standard.

Correction factors

Water temperature °C

Entering air temperature	110/80	120/90	130/100	140/110	150/120
-10	1,05	1,15	1,25	1,35	1,45
-5	1,00	1,10	1,20	1,30	1,40
0	0,95	1,05	1,15	1,25	1,35
+5	0,90	1,00	1,10	1,20	1,30
+10	0,85	0,95	1,05	1,15	1,25
+15	0,80	0,90	1,00	1,10	1,20
+20	0,75	0,85	0,95	1,05	1,15
+25	0,70	0,80	0,90	1,00	1,10

Mounting heights

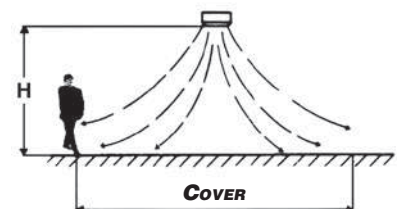
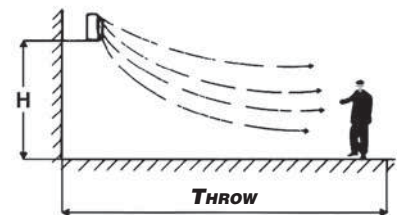

4/6 Pole models – WATER Temperature 160-110°C

Drop 50°C – Δtm 120°C – Entering air temperature 15°C

SIZE	MOTOR SPEED		MODEL		AIR FLOW		NOISE LEVEL AT 5 m (★)		EMISSION		LEAVING AIR TEMPERATURE		POLES	Mounting heights:					
	r.p.m.		Atlas	Helios	m³/h		dB(A)		kW		°C			Horizontal discharge		Vertical discharge			
	4 POLES	6 POLES			4 POLES	6 POLES	4 POLES	6 POLES	4 POLES	6 POLES	4 POLES	6 POLES		HEIGHT m	THROW m	HEIGHT max. m	COVER m²		
1	1350	1000	46A11	46H11	1415	1055	56	50	9,72	8,15	34,0	37,6	4	2,5÷3,5	7,5	3,5	50		
			46A12	46H12	1340	990	56	50	-	-	-	-		-	-	-	-	-	-
			46A13	46H13	1195	885	56	50	-	-	-	-		-	-	-	-	-	-
2	1350	1000	46A21	46H21	2190	1680	59	53	14,47	12,97	34,3	37,6	4	3÷4	10	4	60		
			46A22	46H22	2010	1570	59	53	-	-	-	-		-	-	-	-	-	-
			46A23	46H23	1875	1420	59	53	-	-	-	-		-	-	-	-	-	-
3	1350	1000	46A31	46H31	3325	2510	61	55	21,41	19,11	33,8	37,3	4	3÷4	13,5	5	70		
			46A32	46H32	2915	2255	61	55	-	-	-	-		-	-	-	-	-	-
			46A33	46H33	2610	2040	61	55	-	-	-	-		-	-	-	-	-	-
4	1350	1000	46A41	46H41	4415	3305	64	57	28,80	25,68	34,1	37,7	4	3,5÷4,5	16	5,5	75		
			46A42	46H42	3725	2745	64	57	-	-	-	-		-	-	-	-	-	-
			46A43	46H43	3210	2390	64	57	-	-	-	-		-	-	-	-	-	-
5	1350	1000	46A51	46H51	5770	4250	66	59	37,57	33,33	34,1	37,9	4	4÷5	18	6	90		
			46A52	46H52	4800	3500	66	59	-	-	-	-		-	-	-	-	-	-
			46A53	46H53	4325	3110	66	59	-	-	-	-		-	-	-	-	-	-
6	1350	1000	46A61	46H61	6590	5065	69	62	45,62	40,95	35,3	38,7	4	4÷5,5	22	7	120		
			46A62	46H62	5515	4160	69	62	-	-	-	-		-	-	-	-	-	-
			46A63	46H63	4900	3620	69	62	-	-	-	-		-	-	-	-	-	-

(★) = The sound pressure levels dB(A) are measured at a distance of 5m, directional factor Q=2, compliant with the EN 3744 standard.

Correction factors

Water temperature °C

Entering air temperature	140/90	150/100	160/110	170/120
-10	1,04	1,13	1,21	1,29
-5	1,00	1,08	1,17	1,25
0	0,96	1,04	1,13	1,21
+5	0,92	1,00	1,08	1,17
+10	0,88	0,96	1,04	1,13
+15	0,83	0,92	1,00	1,08
+20	0,79	0,88	0,96	1,04
+25	0,75	0,83	0,92	1,00

Mounting heights

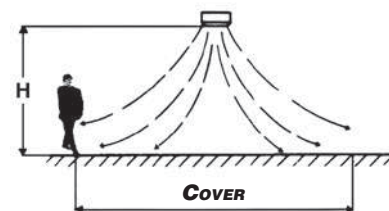
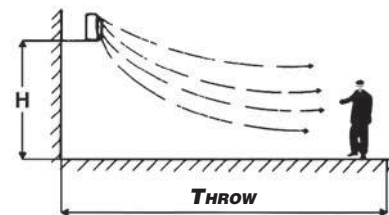

6/8 Pole models – WATER Temperature 160-110°C

Drop 50°C – Δtm 120°C – Entering air temperature 15°C

SIZE	MOTOR SPEED		MODEL		AIR FLOW		NOISE LEVEL AT 5 m (*)		EMISSION		LEAVING AIR TEMPERATURE		POLES	Mounting heights:			
	r.p.m.				m³/h		dB(A)		kW		°C			Horizontal discharge		Vertical discharge	
	6 POLES	8 POLES	Atlas	Helios	6 POLES	8 POLES	6 POLES	8 POLES	6 POLES	8 POLES	6 POLES	8 POLES		HEIGHT m	THROW m	HEIGHT max. m	COVER m²
1	900	750	68A11	68H11	970	860	48	44	7,84	7,45	38,7	40,4	6	2,5÷3	5	3	36
			68A12	68H12	935	830	48	44	-	-	-	-	8	2,5÷3	4,5	-	-
			68A13	68H13	835	740	48	44	-	-	-	-	-	-	-	-	-
2	900	750	68A21	68H21	1495	1170	50	46	12,34	11,07	39,1	42,7	6	2,5÷3,5	7	3,5	45
			68A22	68H22	1410	1100	50	46	-	-	-	-	8	2,5÷3,5	5,5	-	-
			68A23	68H23	1290	1025	50	46	-	-	-	-	-	-	-	-	-
3	900	750	68A31	68H31	2100	1620	52	48	17,74	15,80	39,7	43,5	6	2,5÷3,5	10	4	50
			68A32	68H32	1880	1470	52	48	-	-	-	-	8	2,5÷3,5	7	-	-
			68A33	68H33	1735	1320	52	48	-	-	-	-	-	-	-	-	-
4	900	750	68A41	68H41	2795	2195	54	50	23,88	21,46	40,0	43,6	6	3÷4	12	4,5	55
			68A42	68H42	2345	1755	54	50	-	-	-	-	8	3÷4	8	-	-
			68A43	68H43	2010	1535	54	50	-	-	-	-	-	-	-	-	-
5	900	750	68A51	68H51	3685	2865	56	51	31,40	28,08	39,9	43,7	6	3,5÷4,5	13	5	70
			68A52	68H52	3050	2335	56	51	-	-	-	-	8	3,5÷4,5	9,5	-	-
			68A53	68H53	2785	2100	56	51	-	-	-	-	-	-	-	-	-
6	900	750	68A61	68H61	4445	3550	59	54	38,73	35,06	40,5	43,9	6	4÷5	16	6	100
			68A62	68H62	3710	2960	59	54	-	-	-	-	8	4÷5	12	-	-
			68A63	68H63	3270	2610	59	54	-	-	-	-	-	-	-	-	-
7	900	750	68A71	-	5100	3960	65	59	47,77	42,65	42,4	46,5	6	4÷5	24	7	120
			68A72	-	4800	3650	65	59	-	-	-	-	8	3,5÷4	18	6	100
			68A73	-	4600	3500	65	59	-	-	-	-	-	-	-	-	-
8	900	750	68A81	-	7650	5400	67	61	61,10	52,54	38,4	43,5	6	4÷5,5	26	9	160
			68A82	-	6900	4950	67	61	-	-	-	-	8	3,5÷4,5	20	7	130
			68A83	-	6300	4500	67	61	-	-	-	-	-	-	-	-	-
9	900	750	68A91	-	10600	7600	68	62	85,69	74,32	38,7	43,6	6	4÷6	28	11	200
			68A92	-	10200	7200	68	62	-	-	-	-	8	3,5÷5	21	8	150
			68A93	-	9400	6400	68	62	-	-	-	-	-	-	-	-	-
10	900	750	68A101	-	12250	9215	71	65	107,63	94,79	40,7	45,1	6	4÷6	30	12	220
			68A102	-	11800	8800	71	65	-	-	-	-	8	4÷5	22	9	160
			68A103	-	11000	7950	71	65	-	-	-	-	-	-	-	-	-

(*) = The sound pressure levels dB(A) are measured at a distance of 5m, directional factor Q=2, compliant with the EN 3744 standard.

Correction factors

Water temperature °C

Entering air temperature	140/90	150/100	160/110	170/120
-10	1,04	1,13	1,21	1,29
-5	1,00	1,08	1,17	1,25
0	0,96	1,04	1,13	1,21
+5	0,92	1,00	1,08	1,17
+10	0,88	0,96	1,04	1,13
+15	0,83	0,92	1,00	1,08
+20	0,79	0,88	0,96	1,04
+25	0,75	0,83	0,92	1,00

Mounting heights

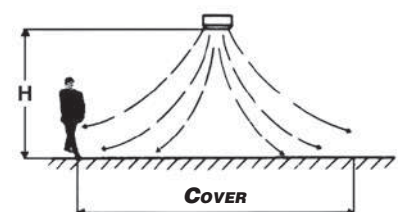
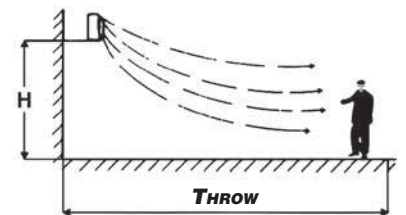

4/6 Pole models – STEAM 6 bar (for steam we recommend the use of copper tube coils)

Steam temperature 164°C – Entering air temperature 15°C

SIZE	MOTOR SPEED		MODEL		AIR FLOW		NOISE LEVEL AT 5 m (*)		EMISSION		LEAVING AIR TEMPERATURE		POLES	Mounting heights:				
	r.p.m.		Atlas	Helios	m³/h		dB(A)		kW		°C			Horizontal discharge		Vertical discharge		
	4 POLES	6 POLES			4 POLES	6 POLES	4 POLES	6 POLES	4 POLES	6 POLES	4 POLES	6 POLES		HEIGHT m	THROW m	HEIGHT max. m	COVER m²	
1	1350	1000	46A11	46H11	1415	1055	56	50	14,11	12,46	44,0	49,0	4	2,5÷3,5	7,5	3,5	50	
			46A12	46H12	1340	990	56	50	-	-	-	-		6	2,5÷3	5	3	36
			46A13	46H13	1195	885	56	50	-	-	-	-						
2	1350	1000	46A21	46H21	2190	1680	59	53	20,88	18,65	42,5	47,1	4	3÷4	10	4	60	
			46A22	46H22	2010	1570	59	53	-	-	-	-		6	2,5÷3,5	7	3,5	45
			46A23	46H23	1875	1420	59	53	-	-	-	-						
3	1350	1000	46A31	46H31	3325	2510	61	55	30,38	26,78	41,5	45,9	4	3÷4	13,5	5	70	
			46A32	46H32	2915	2255	61	55	-	-	-	-		6	2,5÷3,5	10	4	50
			46A33	46H33	2610	2040	61	55	-	-	-	-						
4	1350	1000	46A41	46H41	4415	3305	64	57	40,48	35,55	41,6	46,2	4	3,5÷4,5	16	5,5	75	
			46A42	46H42	3725	2745	64	57	-	-	-	-		6	3÷4	12	4,5	55
			46A43	46H43	3210	2390	64	57	-	-	-	-						
5	1350	1000	46A51	46H51	5770	4250	66	59	52,35	45,70	41,3	46,1	4	4÷5	18	6	90	
			46A52	46H52	4800	3500	66	59	-	-	-	-		6	3,5÷4,5	13	5	70
			46A53	46H53	4325	3110	66	59	-	-	-	-						
6	1350	1000	46A61	46H61	6590	5065	69	62	63,26	56,13	42,8	47,1	4	4÷5,5	22	7	120	
			46A62	46H62	5515	4160	69	62	-	-	-	-		6	4÷5	16	6	100
			46A63	46H63	4900	3620	69	62	-	-	-	-						

(*) = The sound pressure levels dB(A) are measured at a distance of 5m, directional factor Q=2, compliant with the EN 3744 standard.

Correction factors

Bar

Entering air temperature	4	5	6	7	8	10
-10	1,08	1,13	1,17	1,21	1,24	1,30
-5	1,05	1,09	1,13	1,17	1,21	1,26
0	1,01	1,06	1,10	1,14	1,17	1,23
+5	0,98	1,03	1,07	1,11	1,14	1,19
+10	0,95	0,99	1,03	1,07	1,11	1,16
+15	0,91	0,96	1,00	1,04	1,07	1,13
+20	0,88	0,93	0,97	1,01	1,04	1,09
+25	0,85	0,89	0,93	0,97	1,01	1,06

Mounting heights

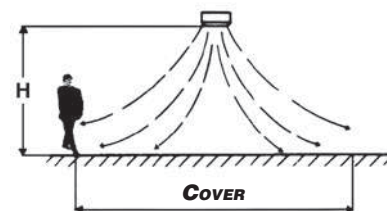
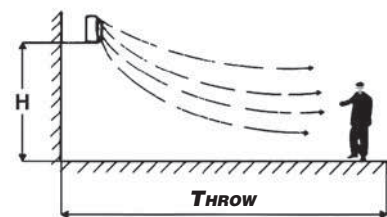

6/8 Pole models – STEAM 6 bar (for steam we recommend the use of copper tube coils)

Steam temperature 164°C – Entering air temperature 15°C

SIZE	MOTOR SPEED		MODEL		AIR FLOW		NOISE LEVEL AT 5 m (*)		EMISSION		LEAVING AIR TEMPERATURE		POLES	Mounting heights:				
	r.p.m.		Atlas	Helios	m³/h		dB(A)		kW		°C			Horizontal discharge		Vertical discharge		
	6 POLES	8 POLES			6 POLES	8 POLES	6 POLES	8 POLES	6 POLES	8 POLES	6 POLES	8 POLES		HEIGHT m	THROW m	HEIGHT max. m	COVER m²	
1	900	750	68A11	68H11	970	860	48	44	11,99	11,36	50,9	53,3	6	2,5÷3	5	3	36	
			68A12	68H12	935	830	48	44	-	-	-	-		8	2,5÷3	4,5	-	-
			68A13	68H13	835	740	48	44	-	-	-	-			-	-	-	
2	900	750	68A21	68H21	1495	1170	50	46	17,71	15,84	49,3	54,2	6	2,5÷3,5	7	3,5	45	
			68A22	68H22	1410	1100	50	46	-	-	-	-		8	2,5÷3,5	5,5	-	-
			68A23	68H23	1290	1025	50	46	-	-	-	-			-	-	-	
3	900	750	68A31	68H31	2100	1620	52	48	24,62	21,70	49,0	53,8	6	2,5÷3,5	10	4	50	
			68A32	68H32	1880	1470	52	48	-	-	-	-		8	2,5÷3,5	7	-	-
			68A33	68H33	1735	1320	52	48	-	-	-	-			-	-	-	
4	900	750	68A41	68H41	2795	2195	54	50	32,85	29,20	49,1	53,5	6	3÷4	12	4,5	55	
			68A42	68H42	2345	1755	54	50	-	-	-	-		8	3÷4	8	-	-
			68A43	68H43	2010	1535	54	50	-	-	-	-			-	-	-	
5	900	750	68A51	68H51	3685	2865	56	51	42,74	37,82	48,6	53,2	6	3,5÷4,5	13	5	70	
			68A52	68H52	3050	2335	56	51	-	-	-	-		8	3,5÷4,5	9,5	-	-
			68A53	68H53	2785	2100	56	51	-	-	-	-			-	-	-	
6	900	750	68A61	68H61	4445	3550	59	54	52,77	47,25	49,4	53,6	6	4÷5	16	6	100	
			68A62	68H62	3710	2960	59	54	-	-	-	-		8	4÷5	12	-	-
			68A63	68H63	3270	2610	59	54	-	-	-	-			-	-	-	
7	900	750	68A71	-	5100	3960	65	59	59,48	52,56	48,8	53,5	6	4÷5	24	7	120	
			68A72	-	4800	3650	65	59	-	-	-	-		8	3,5÷4	18	6	100
			68A73	-	4600	3500	65	59	-	-	-	-			-	-	-	
8	900	750	68A81	-	7650	5400	67	61	81,13	68,72	45,7	51,9	6	4÷5,5	26	9	160	
			68A82	-	6900	4950	67	61	-	-	-	-		8	3,5÷4,5	20	7	130
			68A83	-	6300	4500	67	61	-	-	-	-			-	-	-	
9	900	750	68A91	-	10600	7600	68	62	113,33	96,70	46,0	51,9	6	4÷6	28	11	200	
			68A92	-	10200	7200	68	62	-	-	-	-		8	3,5÷5	21	8	150
			68A93	-	9400	6400	68	62	-	-	-	-			-	-	-	
10	900	750	68A101	-	12250	9215	71	65	141,36	123,05	48,4	53,7	6	4÷6	30	12	220	
			68A102	-	11800	8800	71	65	-	-	-	-		8	4÷5	22	9	160
			68A103	-	11000	7950	71	65	-	-	-	-			-	-	-	

(*) = The sound pressure levels dB(A) are measured at a distance of 5m, directional factor Q=2, compliant with the EN 3744 standard.

Correction factors

Bar

Entering air temperature	4	5	6	7	8	10
-10	1,08	1,13	1,17	1,21	1,24	1,30
-5	1,05	1,09	1,13	1,17	1,21	1,26
0	1,01	1,06	1,10	1,14	1,17	1,23
+5	0,98	1,03	1,07	1,11	1,14	1,19
+10	0,95	0,99	1,03	1,07	1,11	1,16
+15	0,91	0,96	1,00	1,04	1,07	1,13
+20	0,88	0,93	0,97	1,01	1,04	1,09
+25	0,85	0,89	0,93	0,97	1,01	1,06

Mounting heights

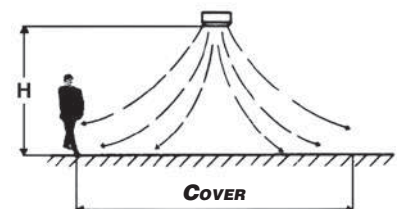
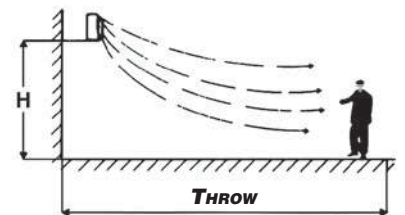

The following tables indicate the pressure drop in m/wg for each **Atlas** and **Helios** model for a mean water temperature of 80°C.

CORRECTION FACTORS FOR DIFFERENT TEMPERATURES

°C	K
50	1.15
60	1.10
70	1.05
90	0.95
100	0.89
110	0.83
120	0.78
130	0.72
140	0.67
150	0.61

1 row

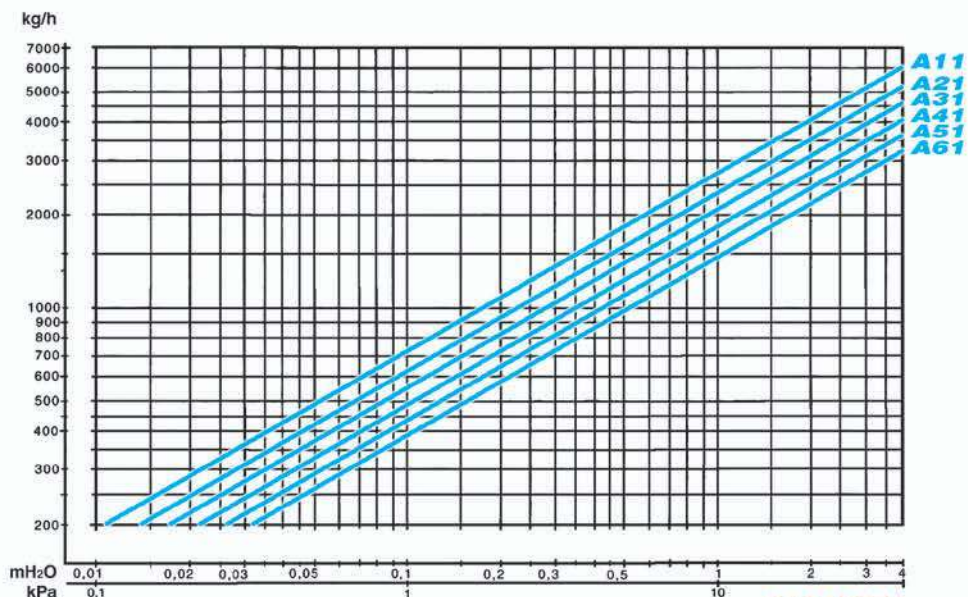

2 rows

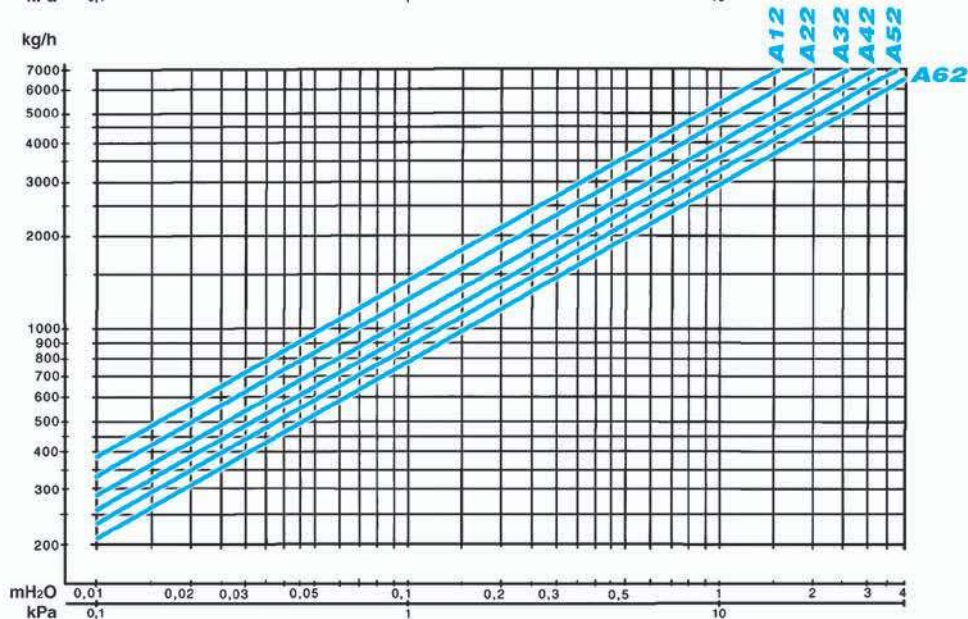

3 rows

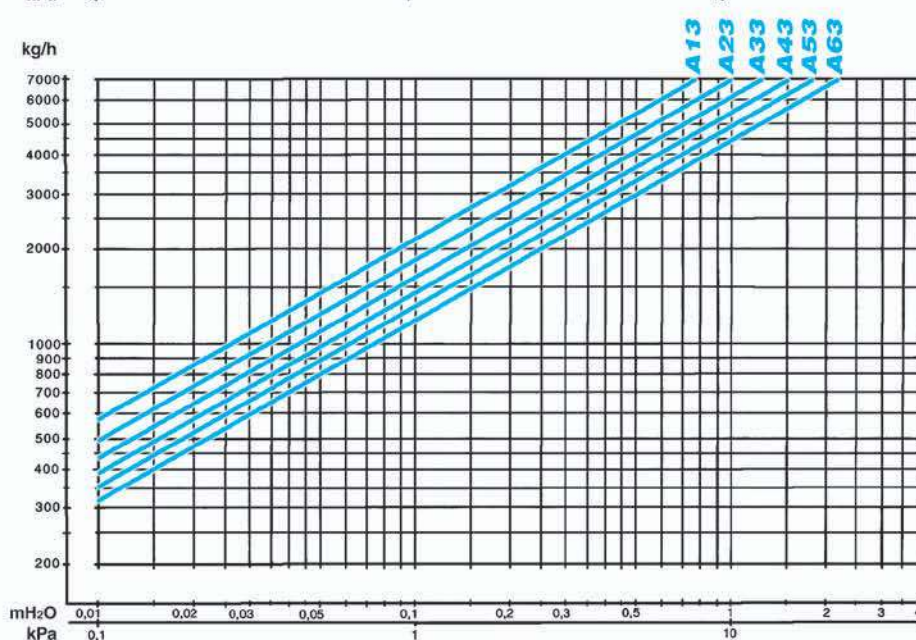

The following tables indicate the pressure drop in m/wg for each **Atlas** model for a mean water temperature of 80°C.

CORRECTION FACTORS FOR DIFFERENT TEMPERATURES

°C	K
50	1.15
60	1.10
70	1.05
90	0.95
100	0.89
110	0.83
120	0.78
130	0.72
140	0.67
150	0.61

1 row

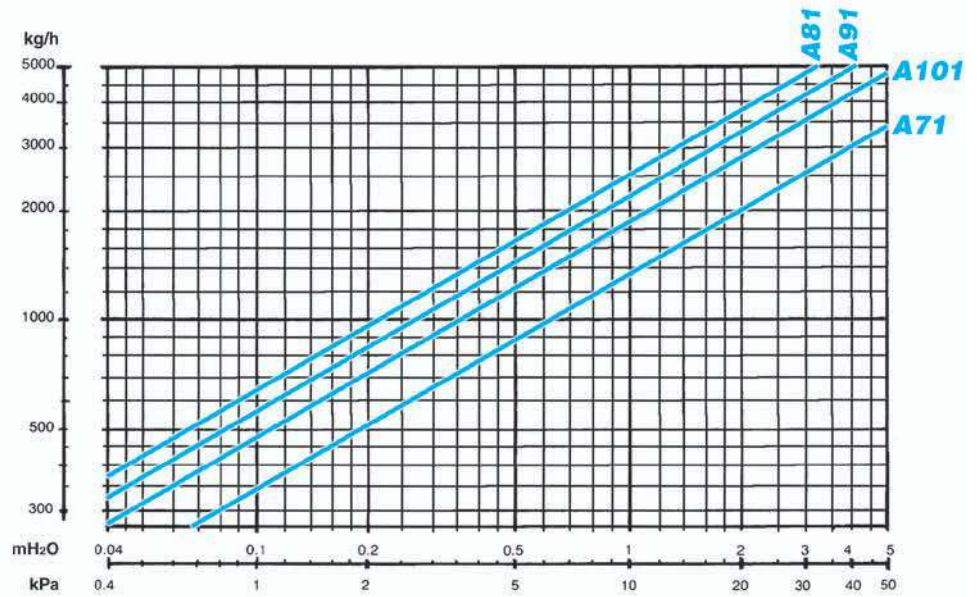

2 rows

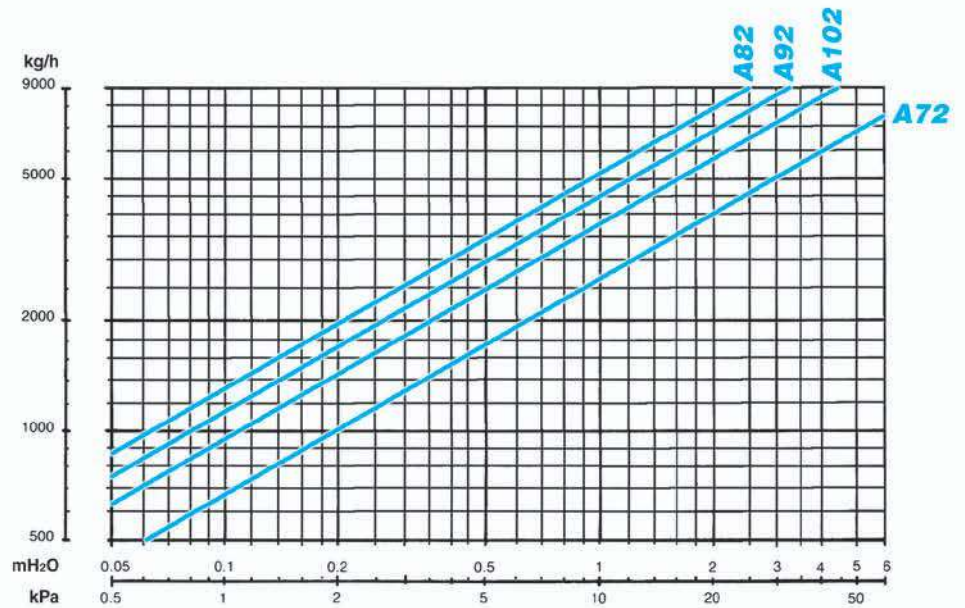

3 rows

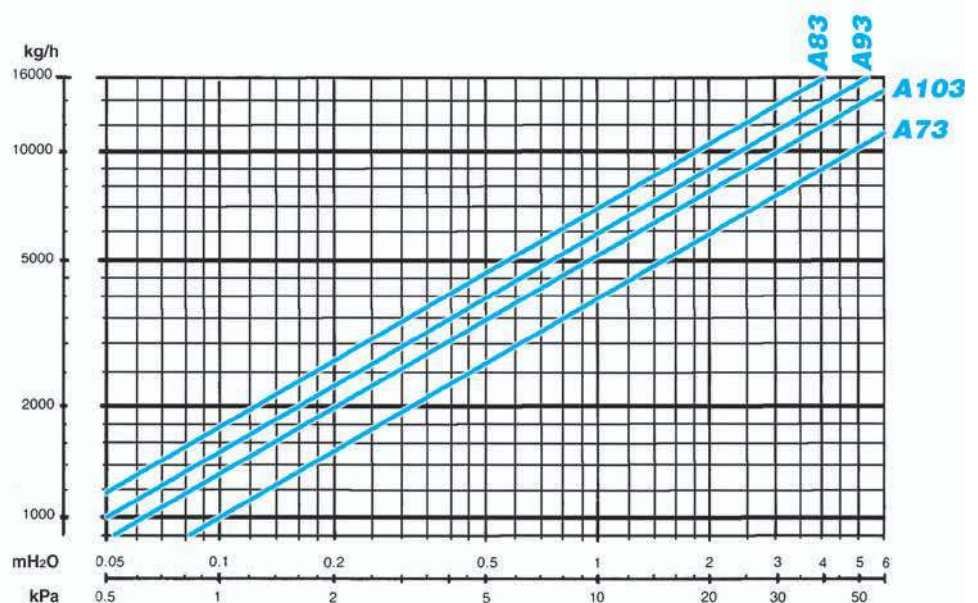



Suitable for use with a chilled water system, **Janus 05** units can be used to economically cool industrial, commercial and sporting facilities, transforming a traditional heating system using unit heaters into a system that can also be used in summer months, significantly improving the working conditions.

The condensate collection tray is built into the unit, while two-speed motors are fitted as standard.

Upon request, controls with thermostat can also be supplied.

The **Janus 05** units are made in 4 sizes, each with 3 and 4 row coils (a total of 8 models) with heat outputs from 16 to 104 kW and cooling capacities from 5 to 28 kW.

The **Janus 05** units are suitable for hot water and chilled water supply, but not suitable for steam supply.

Coil

The heat exchanger (3 or 4 rows) is manufactured from the highest quality copper tube. The fins are pressed from aluminium sheet, bonded onto the tubes facilitating the maximum transfer contact possible.

The heat exchanger is not suitable for use in corrosive atmospheres.

Condensate collection tray, fitted inside the unit.

Electric motor

Asynchronous three phase, single voltage 400V/50Hz, two speeds. Hermetically sealed, IP55 protection, class B insulation.

On request flameproof motor

 **II2GExd IIBT4** (one speed only).

Electric fan support

The finger proof guard also acts as the main support and fixing frame. This frame, made from galvanized steel, is mounted onto the main casing via residually anti-vibration rubber mountings.



Casing

Manufactured from galvanized prepainted steel (1 mm thick) finished in light grey (RAL 9002).

Louvres

Louvres are made from a profiled prepainted steel sheet with a design that allows excellent direction of air flow. The adjustable louvres are held in place by spring loaded pivots which allow the rotation of every single louvre in the desired position without vibrations.

Janus 05 version – Operation limits

Maximum hot water temperature = max. 120°C

WATER

Minimum chilled water temperature = 7°C

Maximum working pressure = 1600 kPa (16 bars)

Reference: 46F43

46	F	4	3
MOTOR 4/6 POLE (1350/1000 r.p.m.)	RANGE JANUS	SIZE 4	ROWS 3

Janus 05 version – Dimensions, Weight, Water content

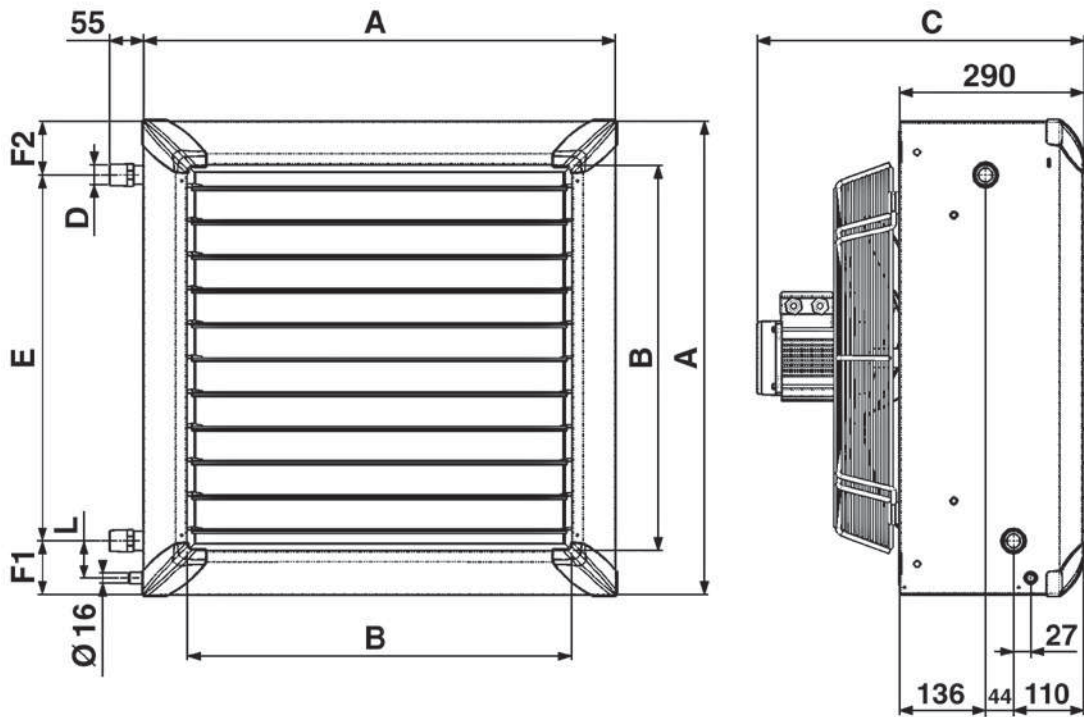

MODEL	Dimensions (mm)								Weight (kg)		Water content (liters)	
	A	B	C	D	E	F1	F2	L	3R	4R	3R	4R
46 F 23/24	526	390	500	1"	376	78	71	58	25,0	26,0	1,7	2,2
46 F 43/44	634	498	500	1"	476	76	83	58	32,5	34,0	2,7	3,4
68 F 63/64	742	606	525	1"	576	83	83	58	42,5	44,5	4,0	5,1
68 F 93/94	1010	874	650	1 ¼"	818	90	100	67	77,0	81,0	7,6	9,8

MODEL	46		46		46		46		68		68		68		68		
	F		F		F		F		F		F		F		F		
	23		24		43		44		63		64		93		94		
Mounting height	m	2.5 ÷ 4				3 ÷ 4.5				3 ÷ 5				3.5 ÷ 5.5			
Speed	r.p.m.	1350	1000	1350	1000	1350	1000	1350	1000	950	750	950	750	950	750	950	750
Air flow	m³/h	2000	1365	1800	1270	3450	2290	3100	2000	3930	3050	3510	2650	7500	5800	6800	5100
Throw	m	11	7,5	10	6,5	16	12	15	11	16	12	15	11	26	20	25	19
Noise level at 5 m. (★)	dB(A)	59	51	59	51	64	54	64	54	60	52	60	52	66	60	66	60
Water temperature 45/40°C – Δt 5°C	kW	8,47	6,65	9,66	7,62	14,44	11,15	16,55	12,27	18,81	15,77	20,67	16,95	37,97	32,04	42,29	34,43
Entering air temperature +15°C	Leaving air temp. °C	27,4	29,3	30,7	32,6	27,3	29,2	30,6	32,9	29,0	30,4	32,2	33,7	29,8	31,2	33,2	34,8
Water temperature 85/75°C – Δt 10°C	kW	20,75	16,23	23,58	18,52	35,15	27,08	40,14	29,66	45,46	38,07	49,79	40,75	92,37	77,80	102,66	83,31
Entering air temperature +15°C	Leaving air temp. °C	43,4	49,8	53,3	57,7	44,8	49,6	52,9	58,4	48,8	52,1	56,5	60,0	51,0	54,2	59,2	62,8
Water temperature 90/70°C – Δt 20°C	kW	19,86	15,63	22,76	18,00	33,86	26,26	39,04	29,10	44,38	37,26	48,95	40,28	89,39	75,66	100,11	81,73
Entering air temperature +15°C	Leaving air temp. °C	44,0	48,5	52,0	56,5	43,7	48,5	51,8	57,6	48,0	51,3	55,8	59,5	49,9	53,2	58,1	61,9

(★) = The sound pressure levels dB(A) are measured at a distance of 5m, directional factor Q=2, compliant with the EN 3744 standard.

Correction factors

for different working conditions

Entering air temperature °C	on 45/40°C Δt 5°C					on 85/75°C Δt 10°C					on 90/70°C Δt 20°C				
	WATER TEMPERATURE °C					WATER TEMPERATURE °C					WATER TEMPERATURE °C				
	40 35	45 40	50 45	55 50	60 55	70 60	75 65	80 70	85 75	90 80	70 50	80 60	85 65	90 70	95 75
-5	1,46	1,62	1,77	1,94	2,10	1,07	1,15	1,23	1,30	1,38	1,00	1,15	1,23	1,31	1,38
0	1,29	1,46	1,62	1,77	1,94	1,00	1,07	1,15	1,23	1,30	0,92	1,08	1,15	1,23	1,31
+5	1,13	1,29	1,46	1,62	1,77	0,92	1,00	1,07	1,15	1,23	0,85	1,00	1,08	1,15	1,23
+10	1,00	1,13	1,29	1,46	1,62	0,84	0,92	1,00	1,07	1,15	0,77	0,92	1,00	1,08	1,15
+15	0,81	1,00	1,13	1,29	1,46	0,76	0,84	0,92	1,00	1,07	0,69	0,85	0,92	1,00	1,08
+20	0,65	0,81	1,00	1,13	1,29	0,69	0,76	0,84	0,92	1,00	0,62	0,77	0,85	0,92	1,00
+25	0,49	0,65	0,81	1,00	1,13	0,62	0,69	0,76	0,84	0,92	0,54	0,69	0,77	0,85	0,92

MODEL		46 F 23	46 F 24	46 F 43	46 F 44	68 F 63	68 F 64	68 F 93	68 F 94
Mounting height	m	2.5 ÷ 4		3 ÷ 4.5		3 ÷ 5		3.5 ÷ 5.5	
Speed	r.p.m.	1000	1000	1000	1000	750	750	750	750
Air flow	m³/h	1365	1270	2290	2000	3050	2650	5800	5100
Throw	m	7,5	6,5	12	11	12	11	20	19
Noise level at 5 m. (★)	dB(A)	51	51	54	54	52	52	60	60
Water temperature 7/12°C – Δt 5°C	kW Total	5,00	6,08	8,62	10,28	13,08	15,28	23,24	26,89
	kW Sensible	3,57	4,14	6,05	6,78	8,79	9,78	16,09	17,75
Entering air temp. +28°C Relative humidity 55%	Leaving air temp. °C	20,1	18,1	20,0	17,7	19,9	16,8	19,6	17,4
	kW Total	3,57	4,27	6,21	7,32	9,33	10,89	16,56	19,08
Water temperature 11/15°C – Δt 4°C	kW Sensible	3,25	3,62	5,43	5,86	7,61	8,28	14,28	15,38
	Leaving air temp. °C	20,8	19,4	20,8	19,1	20,3	18,5	20,5	18,9
Water temperature 9/14°C – Δt 5°C	kW Total	4,02	4,90	6,93	8,34	10,62	12,51	18,76	21,74
	kW Sensible	3,31	3,79	5,51	6,11	7,91	8,75	14,66	16,07
Entering air temp. +28°C Relative humidity 55%	Leaving air temp. °C	20,6	19,0	20,7	18,7	20,0	18,0	20,3	18,4

(★) = The sound pressure levels dB(A) are measured at a distance of 5m, directional factor Q=2, compliant with the EN 3744 standard.

Correction factors (kW total)

for different working conditions

Entering air temp. °C	on 7/12°C Δt 5°C			on 11/15°C Δt 4°C		
	WATER TEMPERATURE °C			WATER TEMPERATURE °C		
	7 12	8 13	9 14	9 13	10 14	11 15
+26	0,79	0,71	0,63	0,99	0,85	0,74
+27	0,89	0,80	0,71	1,14	1,00	0,85
+28	1,00	0,90	0,80	1,30	1,15	1,00
+29	1,11	1,00	0,88	1,46	1,31	1,16
+30	1,23	1,10	0,98	1,62	1,47	1,32

The **Janus 05** air conditioners not only cool the air, but also feature a dehumidification function. When the unit operates in climatic conditions where the dehumidification function prevails (for example, when first starting the unit), some droplets of atomised condensate may be released by the unit. This should be kept in mind during installation, so as to avoid causing disturbance to persons or objects. **The chilled water flow should always be shut off when the fan stops.**

Janus 05 version – Water side pressure drop (kPa)

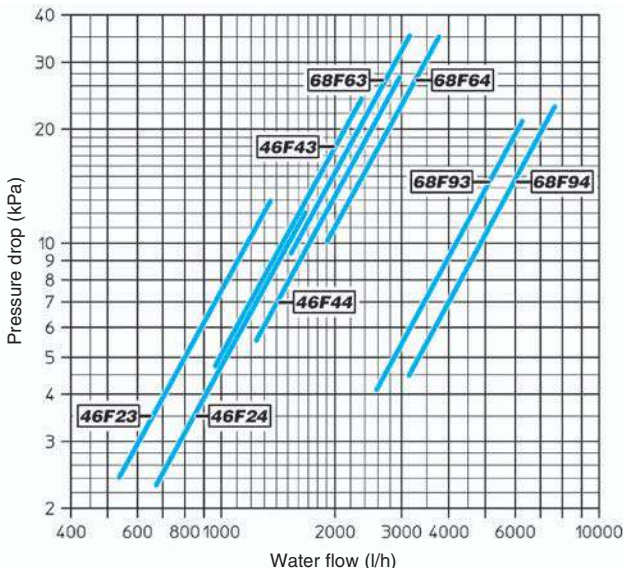

The water pressure drop figures refer to a mean water temperature of **10°C**; for different temperature, multiply the pressure drop figures by the correction factors **K**.

TMW °C	40	50	60	70	80
K	0,86	0,82	0,78	0,74	0,70



AIX Sabiana unit heaters are made with stainless steel casing and coil with stainless steel pipes and aluminium fins, with flanged fittings.

They are available in four sizes (total of eight models). These units can be supplied with hot water, high temperature hot water and steam.

Coil

The fins are pressed from an aluminium sheet, bonded onto the AISI 304 stainless steel tubes and are supplied with flanged connections (counter flanges not included).

Electric motor

Asynchronous three phase, single voltage 400V/50 Hz, two speeds. Hermetically sealed, IP55 protection, class B insulation.

Electric fan support

The finger proof guard also acts as the main support and fixing frame.

This frame, made from galvanized steel painted with epoxy polyester coat (colour RAL 9002) and dried in a furnace at 180°C, is mounted onto the main casing via residually anti-vibration rubber mountings.

Casing

Manufactured from AISI 304 stainless steel, 1 mm thick.

The adjustable louvres are held in place by spring loaded pivots and they are mounted in a horizontal position on the front of the unit.



AIX version – Operation limits

WATER	Maximum water temperature = max. 210°C
	Maximum working pressure = 2000 kPa (20 bar)
STEAM	Maximum working pressure = 2000 kPa (20 bar)

Reference: 46I42

46	I	4	2
MOTOR 4/6 POLE (1350/1000 r.p.m.)	RANGE AIX	SIZE 4	ROWS 2

AIX version – Dimensions, Weight, Water content

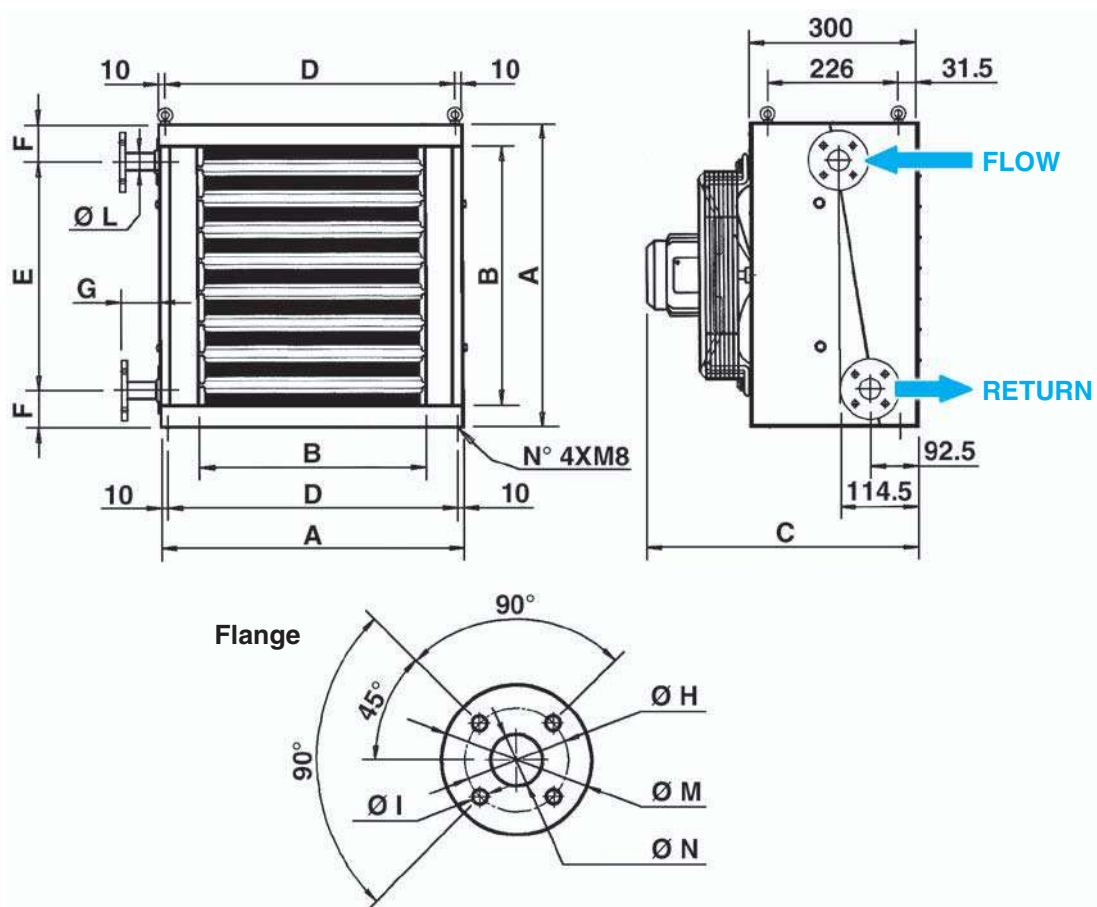

MODEL	Dimensions (mm)												Weight (kg)		Water content (liters)	
	A	B	C	D	E	F	G	ØH	ØI	ØL	ØM	ØN	1R	2R	1R	2R
46 I 21-22	526	393	468	506	330	98	66	65	14	1 1/2"	95	15	26	30	1,7	2,5
46 I 41-42	636	501	468	616	497	69,5	66	85	14	1"	115	25	33	38	2,9	4,2
46 I 61-62	743	609	468	723	588	44,5	56	100	18	1 1/4"	140	32	45	51	5,3	5,9
68 I 91-92	1011	877	576	991	832	89,5	87	110	18	1 1/2"	150	40	82	92	8,2	12

MODEL		46 I 21		46 I 41		46 I 61		68 I 91	
Mounting height	m	2.5 ÷ 4		3 ÷ 4.5		3 ÷ 5		3.5 ÷ 5.5	
Speed	r.p.m.	1350	1000	1350	1000	1350	1000	900	700
Air flow	m³/h	2300	1500	3900	2600	6900	4400	10200	7600
Throw	m	11	7,5	16	12	25	18	28	21
Noise level at 5 m. (★)	dB(A)	59	51	64	54	69	60	68	62
Steam 3 bars	kW	14,3	11,9	23,4	19,8	37	31	68,4	60,5
Entering air temperature +15°C	Leaving air temperature °C	33,3	38,3	32,6	37,4	30,8	35,7	34,7	38,4
Steam 6 bars	kW	16,5	13,8	27	22,9	42,7	35,9	79	70
Entering air temperature +15°C	Leaving air temperature °C	36,1	42	35,4	40,9	33,2	39	37,8	42,1

MODEL		46 I 22		46 I 42		46 I 62		68 I 92	
Mounting height	m	2.5 ÷ 4		3 ÷ 4.5		3 ÷ 5		3.5 ÷ 5.5	
Speed	r.p.m.	1350	1000	1350	1000	1350	1000	900	700
Air flow	m³/h	2100	1400	3600	2400	6300	4100	9200	7000
Throw	m	11	7,5	16	12	25	18	28	21
Noise level at 5 m. (★)	dB(A)	59	51	64	54	69	60	68	62
Water temperature 85/75°C	kW	13	10,6	21,1	17,2	36,5	29,3	59,2	51,4
Entering air temperature +15°C	Leaving air temperature °C	33,2	37,3	32,2	36,1	32	36	33,9	36,6
Water temperature 130/100°C	kW	18,9	15,4	30,2	24,7	53,3	43	84,1	74
Entering air temperature +15°C	Leaving air temperature °C	41,5	47,3	39,7	45,3	39,9	45,8	41,9	46,1

(★) = Pressione sonora dB(A) riferita ad una distanza di 5m, fattore direzionale Q=2, conforme alla norma EN 3744.

Correction factors for different working conditions

Entering air temperature °C	on 85/75°C					on 130/100°C					on 6 bar STEAM FIGURES					
	WATER TEMPERATURE °C					WATER TEMPERATURE °C					BAR					
	70 60	75 65	80 70	85 75	90 80	110 80	120 90	130 100	140 110	150 120	1	2	3	4	5	6
-10	1,15	1,23	1,31	1,38	1,45	1,05	1,15	1,25	1,35	1,45	0,87	0,96	1,03	1,08	1,13	1,17
-5	1,07	1,15	1,23	1,30	1,38	1,00	1,10	1,20	1,30	1,40	0,84	0,93	1,00	1,05	1,09	1,13
0	1,00	1,07	1,15	1,23	1,30	0,95	1,05	1,15	1,25	1,35	0,81	0,90	0,96	1,01	1,06	1,10
+5	0,92	1,00	1,07	1,15	1,23	0,90	1,00	1,10	1,20	1,30	0,78	0,86	0,93	0,98	1,03	1,07
+10	0,84	0,92	1,00	1,07	1,15	0,85	0,95	1,05	1,15	1,25	0,74	0,83	0,90	0,95	0,99	1,03
+15	0,76	0,84	0,92	1,00	1,07	0,80	0,90	1,00	1,10	1,20	0,70	0,80	0,86	0,91	0,96	1,00
+20	0,69	0,76	0,84	0,92	1,00	0,75	0,85	0,95	1,05	1,15	0,67	0,76	0,81	0,88	0,93	0,97
+25	0,62	0,69	0,76	0,84	0,92	0,70	0,80	0,90	1,00	1,10	0,64	0,73	0,80	0,85	0,89	0,93

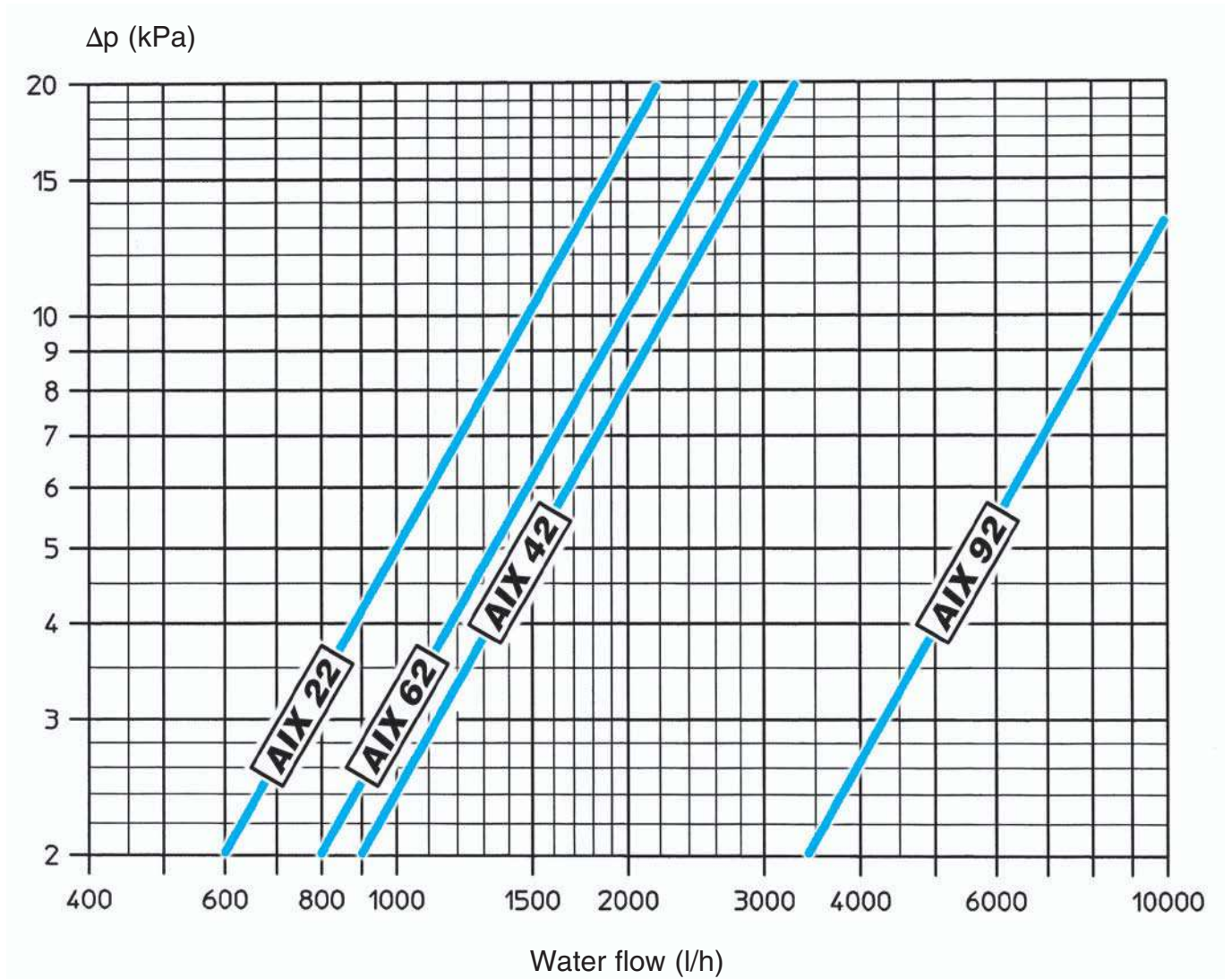

The water pressure drop figures refer to a mean water temperature of **80°C**;
for different temperature, multiply the pressure drop figures by the correction factors **K**.

TMV °C	50	60	70	80	90	100	110	120	130	140	150
K	1,15	1,10	1,05	1,00	0,95	0,89	0,83	0,78	0,72	0,67	0,61



Induction flow optimizer for Atlas, Helios and Janus 05 Sabiana unit heaters

The **Jetstream** induction flow optimizer allows the reduction of the mean leaving air temperature from the unit heaters (Sabiana series Atlas, Helios and Janus 05) and to increase the throw of the equipment with considerable advantages both in terms of energy saving and environment comfort.

The **Jetstream** induction flow optimizers increase the air speed thanks to the special shape of its deflecting louvers which allow the creation of various streams of hot air at the unit heater outlet. The depression created between the layers induces a lateral aspiration of ambient air that mixes with the air heated by the unit, thus reducing the leaving air temperature and increasing the throw.

The leaving air temperature from the units has a decisive influence on hot air stratification and consequently on energy saving:

for each degree of decrease in ambient temperature there is a 1.5% decrease in energy consumption.

The use of **Jetstream** induction flow optimizer has the following advantages:

a) Energy saving:

- reduced hot air stratification within the building;
- reduced operating time of the units with the same ambient temperature.

Energy saving varies between a minimum of 5% and a maximum of 15%, with maximum payback in two seasons.

b) Environmental comfort advantages:

- increased floor temperature uniformity with greater comfort area;
- possibility to install smaller and quieter units, due to the increase of the throw.

Air flow produced by a unit heater WITHOUT induction flow optimizer

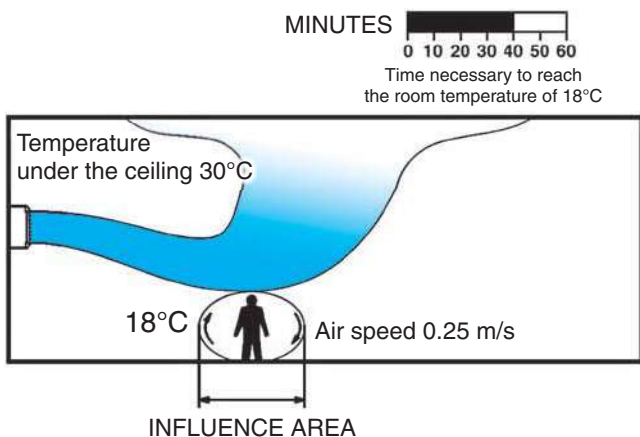

Air flow produced by a unit heater WITH induction flow optimizer

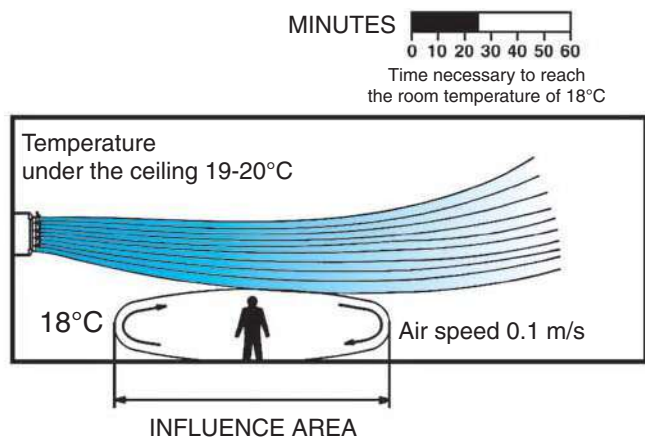

Four versions are available:

- **Manual** for wall installation (horizontal discharge, all sizes)
- **Manual** for ceiling installation (vertical discharge, all sizes)
- **Motorized** for wall installation (horizontal discharge, sizes 1÷7 only)
- **Motorized** for ceiling installation (vertical discharge, all sizes)

The **manually controlled** version calls for manual orientation of the louvres and for them to be locked using a special threaded rod.

The **motorized** version is supplied with single phase motor that can be controlled by the remote switch.



JETSTREAM version – Dimensions and Weight

O (HORIZONTAL DISCHARGE)

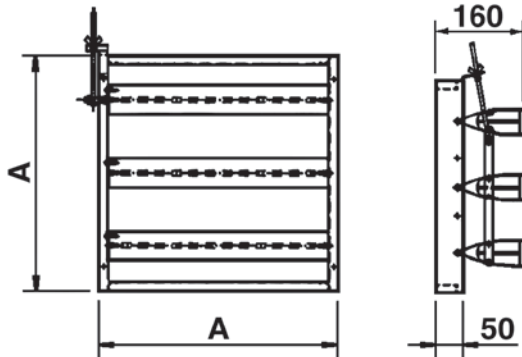

MODEL		A (mm)	Weight (kg)
O - 1	V - 1	368	1,4
O - 2	V - 2	422	1,7
O - 3	V - 3	476	1,8
O - 4	V - 4	530	2,0
O - 5	V - 5	584	2,2
O - 6	V - 6	638	2,4
O - 7	V - 7	793	2,6
O - 8	V - 8	900	3,0
O - 9	V - 9	1010	3,4
O - 10	V - 10	1117	3,7

V (VERTICAL DISCHARGE)

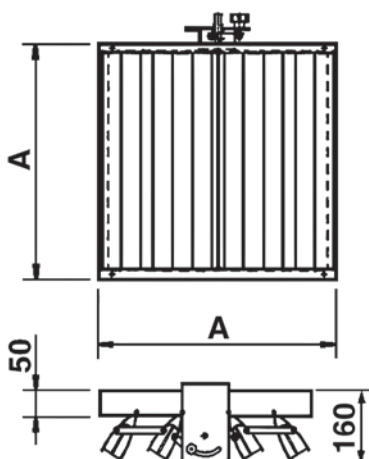

**a) Wall installation
for horizontal discharge:**

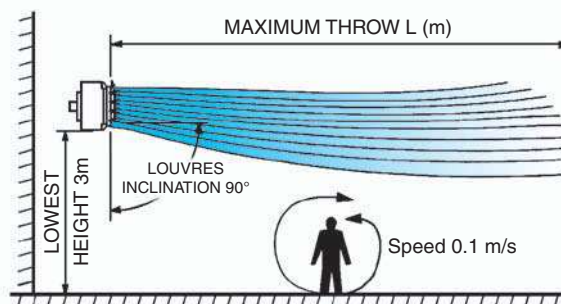

SABIANA UNIT HEATER SIZE	Maximum throw L (m)					
	WITHOUT Jetstream			WITH Jetstream		
	4P	6P	8P	4P	6P	8P
1	7,5	5	4,5	12	8	–
2	10	7	5,5	16	11	–
3	13,5	10	7	18	14	–
4	16	12	8	20	15	–
5	18	13	8	23	16	–
6	22	16	12	28	20	–
7	–	24	18	–	28	22
8	–	26	20	–	32	25
9	–	28	21	–	34	26
10	–	30	22	–	37	28

**b) Ceiling installation
for vertical discharge:**

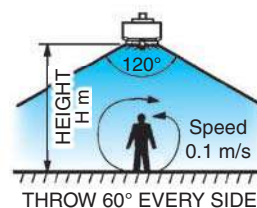
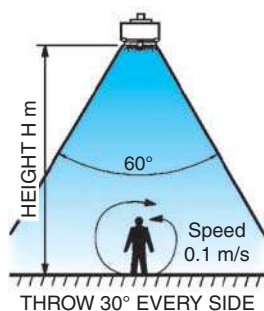

SABIANA UNIT HEATER SIZE	Installation height (m)								
	WITHOUT Jetstream			WITH Jetstream a 60°			WITH Jetstream a 120°		
	4P	6P	8P	4P	6P	8P	4P	6P	8P
1	4	3	–	5,5	4	–	4	3	–
2	4,5	3,5	–	8	6,5	–	5	4	–
3	5	4	–	11	8	–	6,5	5,5	–
4	5,5	4,5	–	12	9	–	6,5	5,5	–
5	6	5	–	13	10	–	7	6	–
6	7	6	–	14	12	–	8	7	–
7	–	7	6	–	13	11	–	8	7
8	–	9	7	–	15	12	–	10	8
9	–	11	8	–	18	13	–	13	9
10	–	12	9	–	19	14	–	14	10



Door Curtain Unit

The **Atlas STP** door curtains, supplied with hot water, are fitted with special diffusers that create a curtain of hot air. Installed above the door, they deliver a constant vertical flow of air, representing a barrier that, by thermodynamic effect, stops the infiltration of air from the outside, and mixes the residual cold currents. Available in three sizes, with two speed and 1, 2, 3 row coils.

Construction

- The main casing is manufactured from galvanized prepainted steel and finished in light grey colour (RAL 9002), and is assembled from three component parts, which are assembled using self-tapping screws in order to allow quick maintenance on the coil.
- Fishtail diffuser produced from a steel sheet with manually adjustable louvres for individual requirements.

Coil

Manufactured from high quality steel or copper tube 22 mm of diameter to reduce resistance with mechanically bonded aluminium fins for high efficient heat transfer. Available in 1, 2 or 3 rows.

Fan and Motor

Consists of aluminium helicoidal blades statically and dynamically balanced with a cast alloy hub, installed into the motor shaft and mounted onto the casing with antivibration rubber mounting blocks. The asynchronous motor is supplied as standard for three phase, 400V 50Hz, class B insulation, IP55 protection, two speed 6/8 poles: 900 r.p.m. (6 poles) or 700 r.p.m. (8 poles).

Installation

It is recommended to select the heaters depending on the size of the door (see table on next page) and the water temperature (see table "Technical characteristics").

Atlas STP version – Dimensions, Weight, Water content

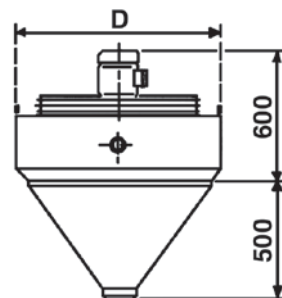
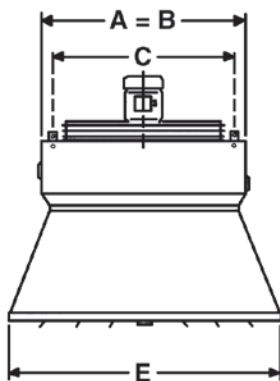

SIZE	Dimensions (mm)				Rows N°	Weight (kg)	Water content (liters)
	A=B	C	D	E			
7	793	696	793	1000	1	62	4,3
					2	70	8,2
					3	76	12,3
8	900	803	900	1200	1	75	5,8
					2	86	11,1
					3	93	16,6
9	1010	913	1010	1400	1	90	7,6
					2	104	14,5
					3	113	21,8

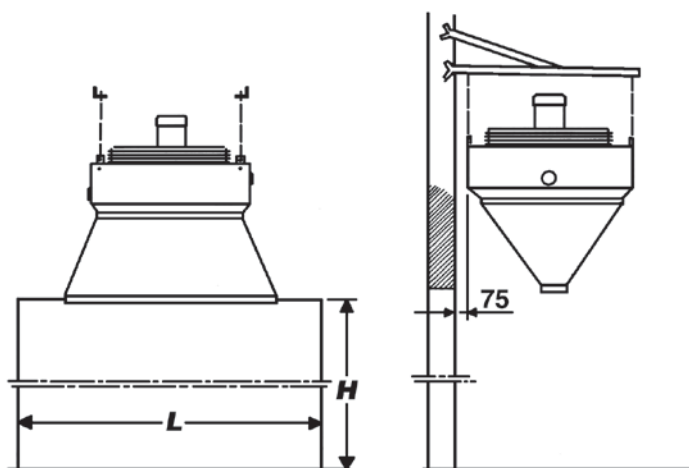

SIZE	Motor pole	Door height H (m)	Door width L (m)
7	6	3.0 ÷ 4.0	1.5
8	6	3.5 ÷ 4.5	2.0
9	6	4.5 ÷ 5.5	2.5
7	8	2.5 ÷ 3.0	1.5
8	8	3.0 ÷ 3.5	1.8
9	8	3.5 ÷ 4.5	2.0

Atlas STP version – Technical characteristics

Entering AIR temperature 15°C

SIZE	MODEL	MOTOR SPEED		AIR FLOW		NOISE LEVEL AT 5 m (*)		Emission							
		r.p.m.		m³/h		dB(A)		Water temperature 85-70°C				Water temperature 140-100°C			
								kW		LEAVING AIR TEMP. °C		kW		LEAVING AIR TEMP. °C	
		6 Poles	8 Poles	6 Poles	8 Poles	6 Poles	8 Poles	6 Poles	8 Poles	6 Poles	8 Poles	6 Poles	8 Poles	6 Poles	8 Poles
7	68A71/STP	900	750	4435	3440	69	63	-	-	-	-	39,42	35,03	41,0	44,8
	68A72/STP	900	750	4175	3175	69	63	38,15	32,87	41,7	45,3	62,72	54,06	59,0	64,8
	68A73/STP	900	750	4000	3045	69	63	44,87	38,06	47,8	51,5	-	-	-	-
8	68A81/STP	900	750	6655	4700	69	64	-	-	-	-	50,62	43,35	37,2	42,0
	68A82/STP	900	750	6000	4300	69	64	49,08	41,20	38,9	43,0	80,12	67,29	54,1	60,8
	68A83/STP	900	750	5480	3915	69	64	59,42	48,49	46,7	51,2	-	-	-	-
9	68A91/STP	900	750	9220	6610	70	65	-	-	-	-	70,80	61,10	37,5	42,0
	68A92/STP	900	750	8870	6260	70	65	70,79	59,10	38,3	42,6	116,23	96,92	53,3	60,3
	68A93/STP	900	750	8170	5560	70	65	86,68	69,00	46,0	51,3	-	-	-	-

(*) = The sound pressure levels dB(A) are measured at a distance of 5m, directional factor Q=2, compliant with the EN 3744 standard.

“2 way valve”

Composed by:

- one 2-way valve
- one ON-OFF 230V actuator

Technical data:

Water flow temperature _____

	Heating	Cooling (*)
Min.	15°C	5°C
Max.	90°C	90°C

(*) **Note:** for Cooling, the valve must be combined with extension kit - code 6034258.

VALVE		IDENTIFICATION	CODE
(Ø)	Kvs		
3/4"	30	VA2V - 3/4"	9008110
1"	50	VA2V - 1"	9008111

2 WAY VALVE



ON-OFF 230V ACTUATOR

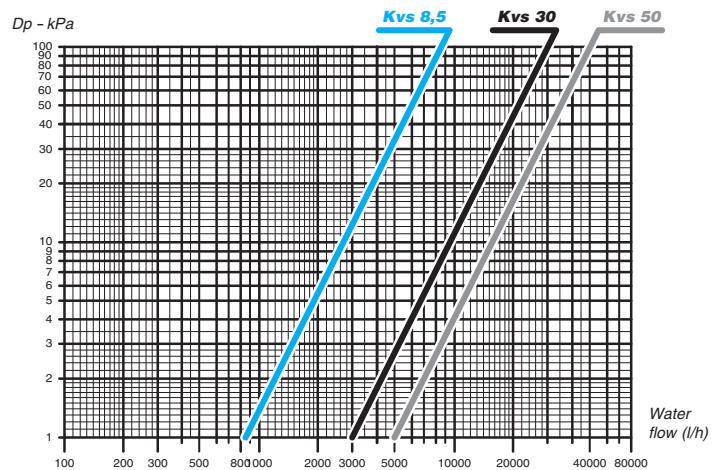
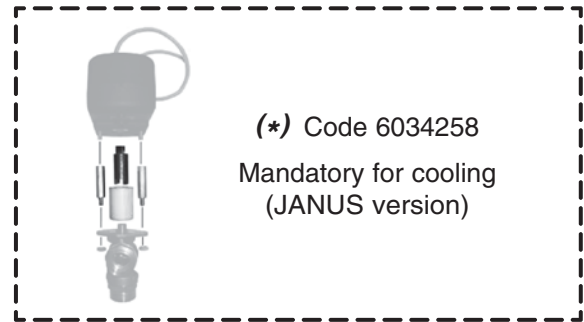

“3 way valve”

Composed by:

- one 3-way valve
- one ON-OFF 230V actuator

Technical data:

Water flow temperature _____

	Heating	Cooling (*)
Min.	15°C	5°C
Max.	90°C	90°C

(*) **Note:** for Cooling, the valve must be combined with extension kit - code 6034258.

VALVE		IDENTIFICATION	CODE
(Ø)	Kvs		
3/4"	8,5	VA3V - 3/4"	9008112

3 WAY VALVE



ON-OFF 230V ACTUATOR

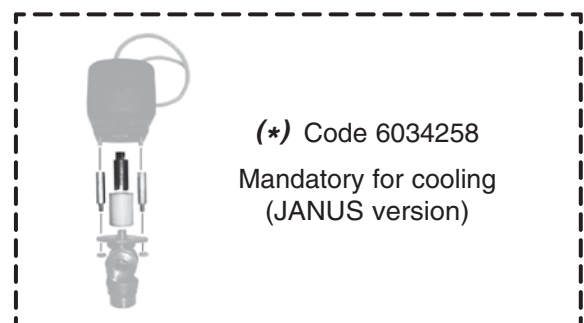

**“AMP” for Atlas and Janus,
“HMP” for Helios**

Wall brackets.
Horizontal discharge.

SIZE	Atlas				Helios				
	A (ATEX)	B	C	D	E	F	G	H	
1	340	(490)	442	157.5	405	310	406	173	436
2	340	(490)	496	184.5	459	310	460	200	490
3	340	(490)	550	211.5	513	310	514	227	544
4	390	(540)	604	238.5	567	360	568	254	598
5	390	(540)	658	265.5	621	360	622	281	652
6	390	(540)	712	292.5	675	360	676	308	706
7	520	(710)	763	318.0	726	-	-	-	-
8	520	(710)	870	371.5	833	-	-	-	-
9	520	(710)	980	426.5	943	-	-	-	-
10	520	(710)	1087	480.0	1050	-	-	-	-

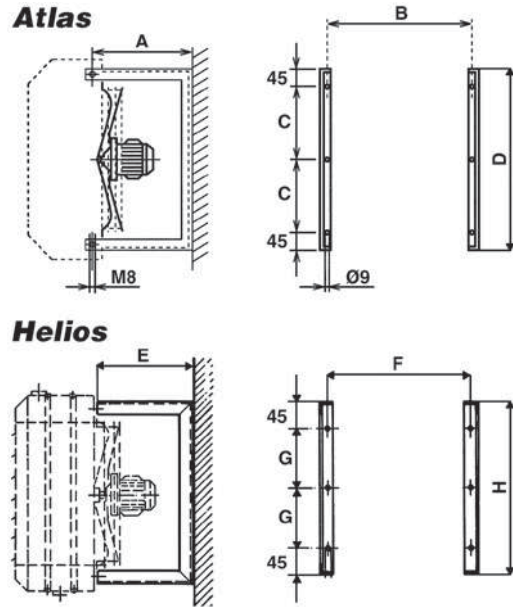

“AS” for Atlas and Janus, “HS” for Helios

Suspension brackets for ceiling installation.
Vertical discharge.

SIZE	A	
	Atlas	Helios
1	375	406
2	429	460
3	483	514
4	537	568
5	591	622
6	645	676
7	696	-
8	803	-
9	913	-
10	1020	-

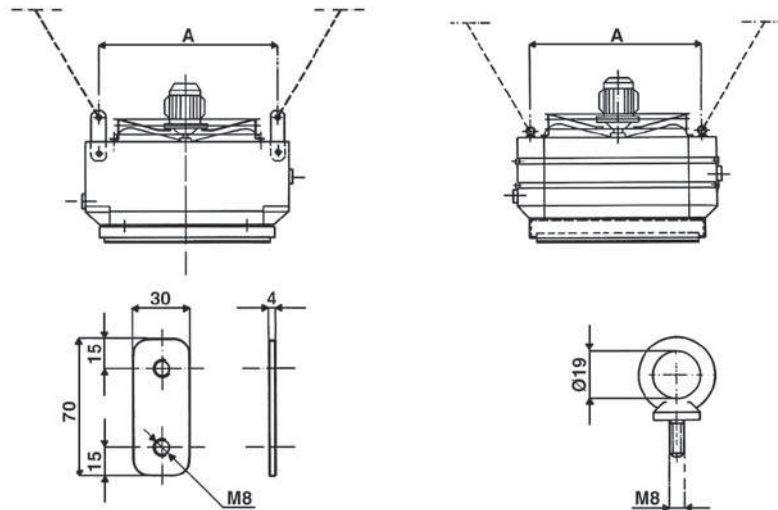

“AF” for Atlas, “HF” for Helios

Water > 140 °C – Steam > 3 bar

Flanged connections. PN 16 flanges are fitted as standard however any flange can be fitted on request.

(Not to be used with ATEX versions).

SIZE	DN	A	B	C
1	20	665	70	160
2	20	719	70	160
3	25	773	70	160
4	25	827	70	160
5	32	881	70	160
6	32	935	70	160
7	40	989	80	150
8	40	1097	80	150
9	40	1205	80	150
10	50	1313	80	150

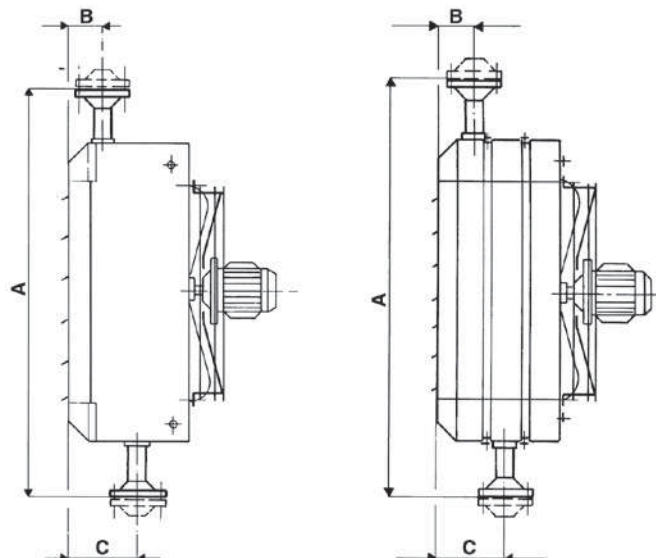

“AD” 4 way diffuser for Atlas, Janus, and Helios

To be used when discharging downflow to create a 4 way discharge pattern.
For normal heights of installation.

SIZE	A	B	WEIGHT
			kg
1	372	336	1,2
2	426	390	1,3
3	480	444	1,5
4	534	498	1,8
5	588	552	1,9
6	642	606	2,1
7	693	657	2,3
8	800	764	2,8
9	910	874	3,0
10	1016	981	3,9

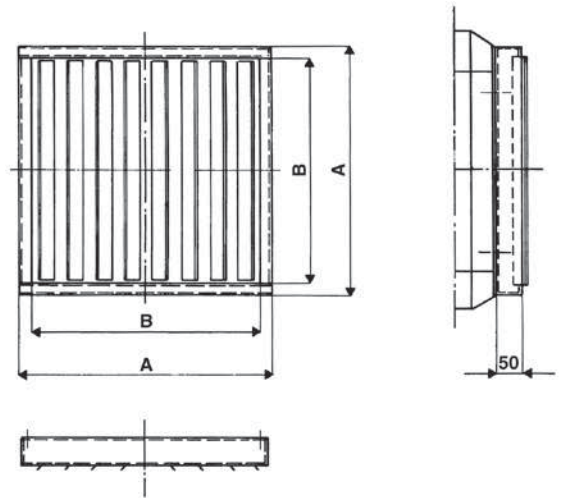

“AW4” for Atlas

To be used when discharging downflow to create a 4 way discharge pattern.
For low heights of installation.
(Not to be used with ATEX versions).

SIZE	A	WEIGHT
		kg
1	376	2,4
2	430	3,0
3	484	3,4
4	538	4,1
5	592	4,6
6	646	5,3

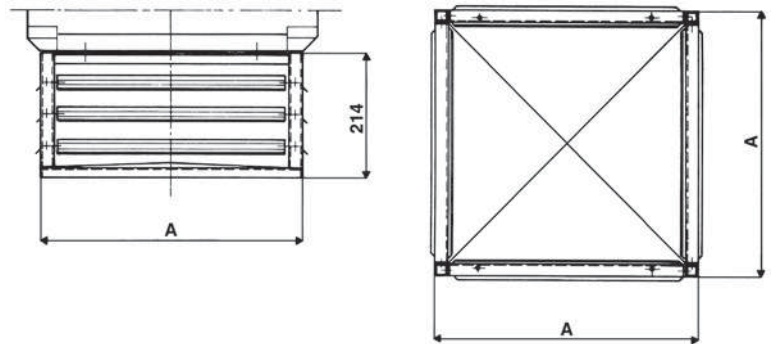

“ATP” for Atlas

Blast nozzle high level diffuser.
Recommended for high ceiling installations.
(Not to be used with ATEX versions).

SIZE	A	B	C	MOUNTING HEIGHTS	WEIGHT
				m	kg
1	336	250	250	3.5 ÷ 4.5	2,9
2	390	250	250	4.5 ÷ 5	3,1
3	444	300	300	5 ÷ 5.5	3,9
4	498	300	300	6 ÷ 6.5	4,7
5	552	350	350	6.5 ÷ 7	5,5
6	606	350	350	7 ÷ 8	6,0
7	657	450	450	7.5 ÷ 8.5	6,2
8	764	450	450	9.5 ÷ 10.5	6,9
9	874	600	600	11.5 ÷ 12.5	7,7
10	981	600	600	12.5 ÷ 13.5	8,5

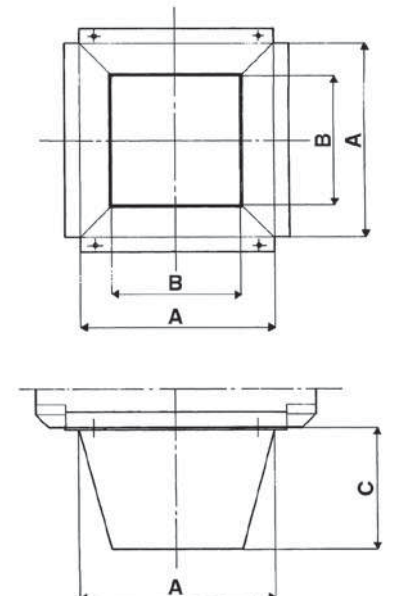

“APP” for Atlas, Janus, and Helios

Ball protection grid.

(Not to be used with ATEX versions).

SIZE	A	WEIGHT
		kg
1	372	2,8
2	426	3,4
3	480	4,2
4	534	5,1
5	588	6,1
6	642	7,0
7	697	8,8
8	804	10,8
9	914	12,9
10	1021	16,0

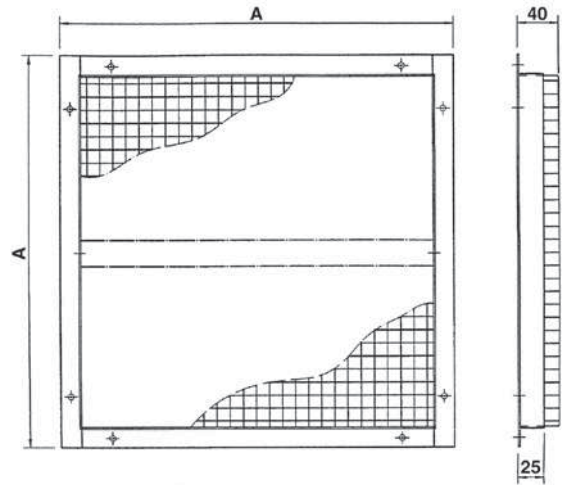

“ARC” for Atlas and Janus

Simple intake hood fitted underneath.

Wall bracket included.

Prepainted steel thickness 1 mm.

(Not to be used with ATEX versions).

SIZE	A	B	C	D	E	F	G	WEIGHT
								kg
1	472	660	1072	600	422	410	370	17,6
2	526	660	1126	600	476	410	370	18,7
3	580	660	1180	600	530	510	370	19,8
4	634	760	1534	900	584	510	470	30,8
5	688	760	1588	900	638	610	470	33,0
6	742	760	1642	900	692	610	470	35,2
7	793	860	1793	1000	710	710	570	44,0
8	900	860	1900	1000	710	710	570	50,6
9	1010	960	2210	1200	910	910	670	63,8
10	1117	960	2317	1200	910	910	670	70,4

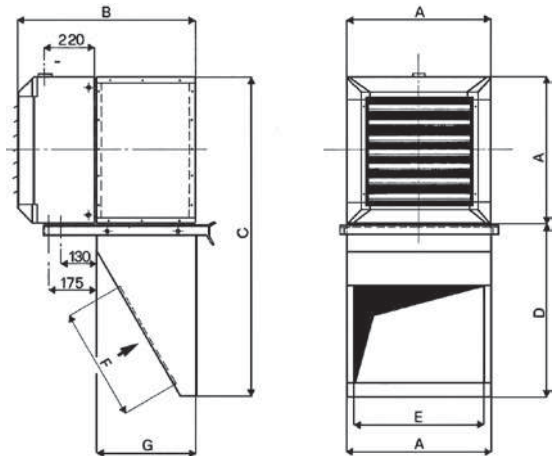

CORRECTION FACTORS
Air volume K 0.90
Heat emission K 0.95

“AMC” for Atlas and Janus

Double intake hood with internal/external air mixing, manually controlled damper.

Wall bracket included. Prepainted steel thickness 1 mm.

(Not to be used with ATEX versions).

SIZE	A	B	C	D	E	F	G	H	WEIGHT
									kg
1	472	660	1072	600	412	410	370	410	18,7
2	526	660	1126	600	466	410	370	410	19,8
3	580	660	1180	600	520	510	370	510	20,9
4	634	760	1534	900	574	510	470	510	31,9
5	688	760	1588	900	628	610	470	610	34,1
6	742	760	1642	900	682	610	470	610	36,3
7	793	860	1793	1000	710	710	570	710	45,1
8	900	860	1900	1000	710	710	570	710	51,7
9	1010	960	2210	1200	910	910	670	910	66,0
10	1117	960	2317	1200	910	910	670	910	72,6

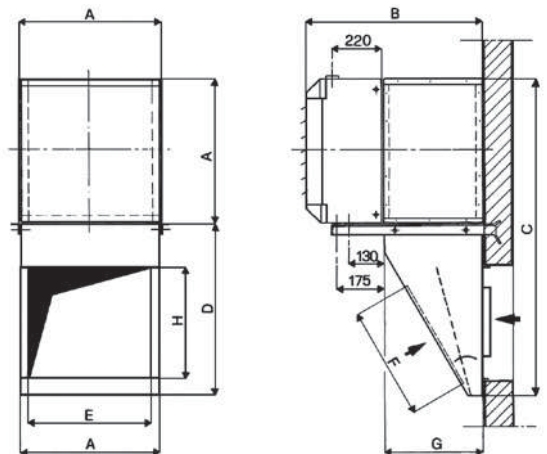

CORRECTION FACTORS
Air volume K 0.90
Heat emission K 0.95

“AP” for Atlas and Janus

Intermediate section for ARC and AMC air boxes.
 Prepainted steel thickness 1 mm.
 (Not to be used with ATEX versions).

SIZE	A	B	WEIGHT (500 mm)	WEIGHT (1000 mm)
			kg	kg
1	472	370	9,9	17,6
2	526	370	9,9	18,7
3	580	370	11,0	19,8
4	634	470	12,1	23,1
5	688	470	13,2	24,2
6	742	470	13,2	25,3
7	793	570	15,4	27,5
8	900	570	16,5	29,7
9	1010	670	18,7	34,1
10	1117	670	19,8	36,3

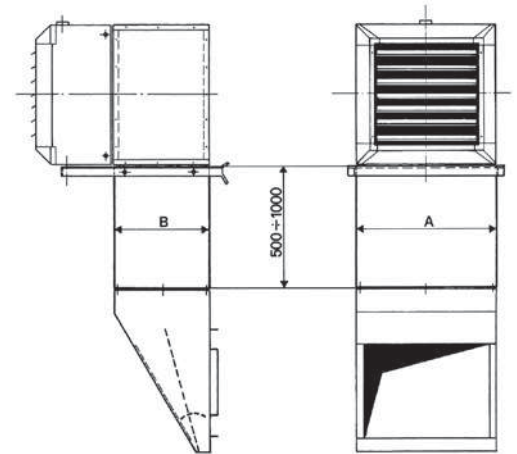

CORRECTION FACTORS	
Air volume K 0.96	
Heat emission K 0.97	

“AE” for Atlas and Janus

Fresh box.
 Prepainted steel thickness 1 mm.
 (Not to be used with ATEX versions).

SIZE	A	B	C	D	E	WEIGHT
						kg
1	472	660	370	412	410	8,8
2	526	660	370	466	410	9,9
3	580	660	370	520	510	11,0
4	634	760	470	574	510	14,3
5	688	760	470	628	610	15,4
6	742	760	470	682	610	16,5
7	793	860	570	710	710	20,9
8	900	860	570	710	710	25,3
9	1010	960	670	910	910	30,8
10	1117	960	670	910	910	35,2

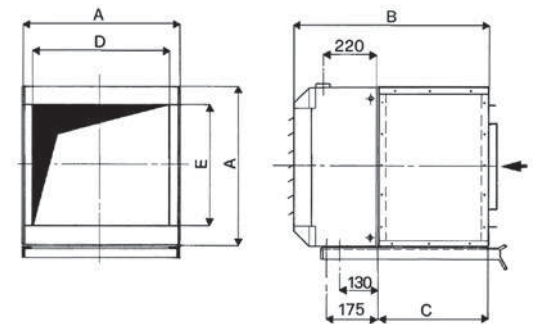

CORRECTION FACTORS	
Air volume K 0.95	
Heat emission K 0.97	

“AES” for Atlas and Janus

Fresh air box with manually operated damper
 (can be motorized by the customer).
 Prepainted steel thickness 1 mm.
 (Not to be used with ATEX versions).

SIZE	A	B	C	D	E	WEIGHT
						kg
1	472	660	370	412	410	16,5
2	526	660	370	466	410	16,5
3	580	660	370	520	510	18,7
4	634	760	470	574	510	24,2
5	688	760	470	628	610	26,4
6	742	760	470	682	610	28,6
7	793	860	570	710	710	33,0
8	900	860	570	710	710	37,4
9	1010	960	670	910	910	47,3
10	1117	960	670	910	910	51,7

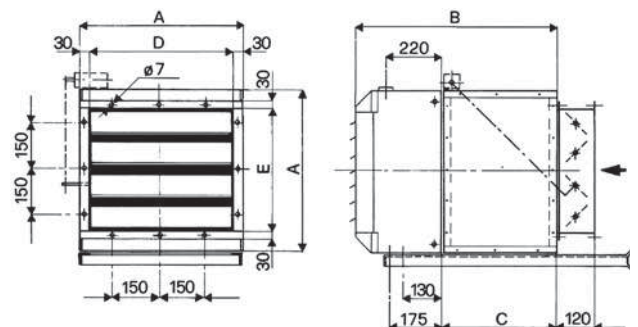

CORRECTION FACTORS	
Air volume K 0.90	
Heat emission K 0.95	

“AG” for Atlas and Janus

External air intake grille suitable with AE-AES-AMC air boxes.
 Prepainted steel thickness 1 mm.

(Not to be used with ATEX versions).

SIZE	A	B	C	D	WEIGHT	
					kg	
1	402	400	410	412	3,9	
2	456	400	410	466	4,6	
3	510	500	510	520	5,4	
4	564	500	510	574	6,2	
5	618	600	610	628	6,9	
6	672	600	610	682	7,7	
7	702	702	712	712	8,5	
8	702	702	712	712	9,2	
9	902	902	912	912	13,2	
10	902	902	912	912	13,2	

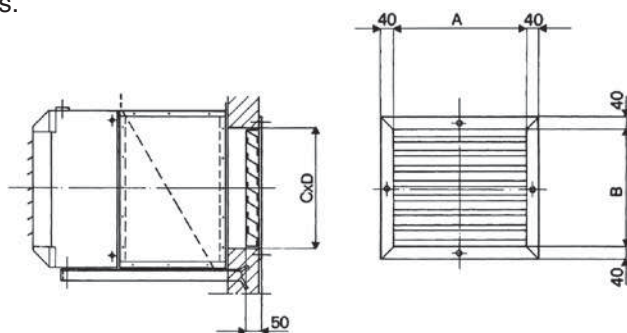

CORRECTION FACTORS
Air volume K 0.97
Heat emission K 0.97

“AM” for Atlas and Janus

Internal/external air mixing box manually controlled.
 Prepainted steel thickness 1 mm.

(Not to be used with ATEX versions).

SIZE	A	B	C	D	E	F	WEIGHT	
							kg	
1	472	660	370	412	410	190	12,1	
2	526	660	370	466	410	190	13,2	
3	580	660	370	520	510	190	15,4	
4	634	760	470	574	510	270	18,7	
5	688	760	470	628	610	300	19,8	
6	742	760	470	682	610	300	22,0	
7	793	860	570	710	710	300	26,4	
8	900	860	570	710	710	300	36,3	
9	1010	960	670	910	910	350	38,5	
10	1117	960	670	910	910	350	45,1	

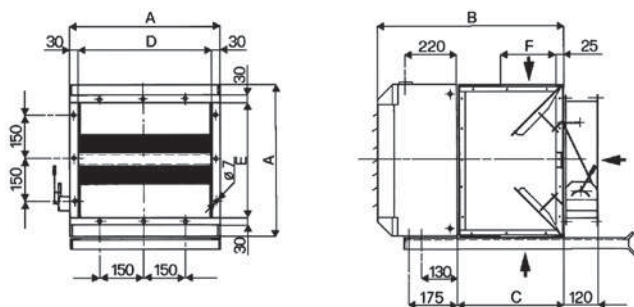

CORRECTION FACTORS
Air volume K 0.90
Heat emission K 0.95

“AMS” for Atlas and Janus

Internal/external air mixing box, manually controlled
 (can be motorized by customer).
 Prepainted steel thickness 1 mm.

(Not to be used with ATEX versions).

SIZE	A	B	C	D	E	F	WEIGHT	
							kg	
1	472	660	370	412	410	310	22,0	
2	526	660	370	466	410	310	23,1	
3	580	660	370	520	510	310	25,3	
4	634	760	470	574	510	410	33,0	
5	688	760	470	628	610	410	35,2	
6	742	760	470	682	610	410	37,4	
7	793	860	570	710	710	510	45,1	
8	900	860	570	710	710	510	49,5	
9	1010	960	670	910	910	610	61,6	
10	1117	960	670	910	910	610	66,0	

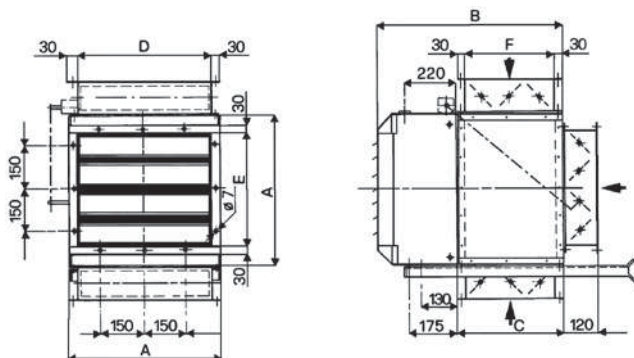

CORRECTION FACTORS
Air volume K 0.90
Heat emission K 0.95

“AC” for Atlas

Intermediate section for AE-AES-AM-AMS air boxes.
 (Not to be used with ATEX versions).

SIZE	A	B	WEIGHT (500 mm)	WEIGHT (1000 mm)
			kg	kg
1	412	410	5,5	10,5
2	466	410	6,6	12,5
3	520	510	6,6	12,5
4	574	510	7,7	14,7
5	628	610	8,8	16,8
6	682	610	8,8	16,8
7	710	710	8,8	16,8
8	710	710	8,8	16,8
9	910	910	12,1	23,0
10	910	910	12,1	23,0

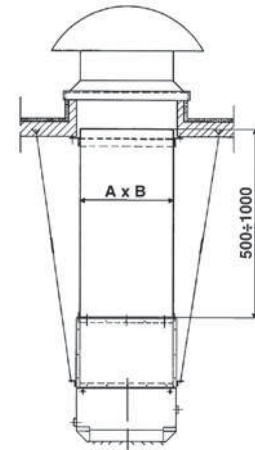

CORRECTION FACTORS
Air volume K 0.96
Heat emission K 0.97

“AT” for Atlas

Roof-mounted air intake suitable with AE-AES-AM-AMS air boxes.
 (Not to be used with ATEX versions).

SIZE	A	B	C	D	E	F	G	H	WEIGHT
									kg
1	412	410	422	420	710	730	600	515	22,0
2	466	410	476	420	710	730	600	515	22,0
3	520	510	530	520	910	920	690	620	28,6
4	574	510	584	520	910	920	690	620	28,6
5	628	610	638	620	990	1220	920	670	39,6
6	682	610	692	620	990	1220	920	670	39,6
7	710	710	870	870	1210	1530	1170	800	57,2
8	710	710	870	870	1210	1530	1170	800	57,2
9	910	910	920	920	1210	1530	1170	800	57,2
10	910	910	920	920	1210	1530	1170	800	57,2

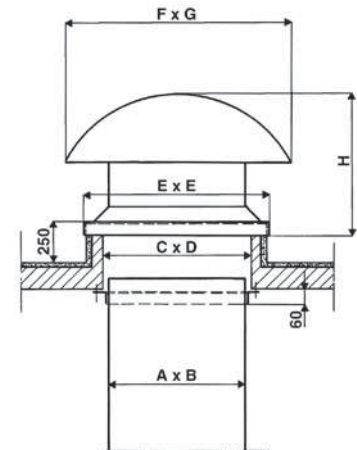

CORRECTION FACTORS
Air volume K 0.97
Heat emission K 0.97

Two speed Delta-Star motors, with Klixon thermic protection

Atlas/Helios/Janus 05/Atlas STP unit heaters are supplied with 4/6 pole or 6/8 pole sliding motors.

With these motors it is possible to reduce the speed changing the connection from delta to star.

These motors are: three phase, single voltage, 400V – 50Hz, IP 55 protection, with klixon thermal protection.

Connection diagram

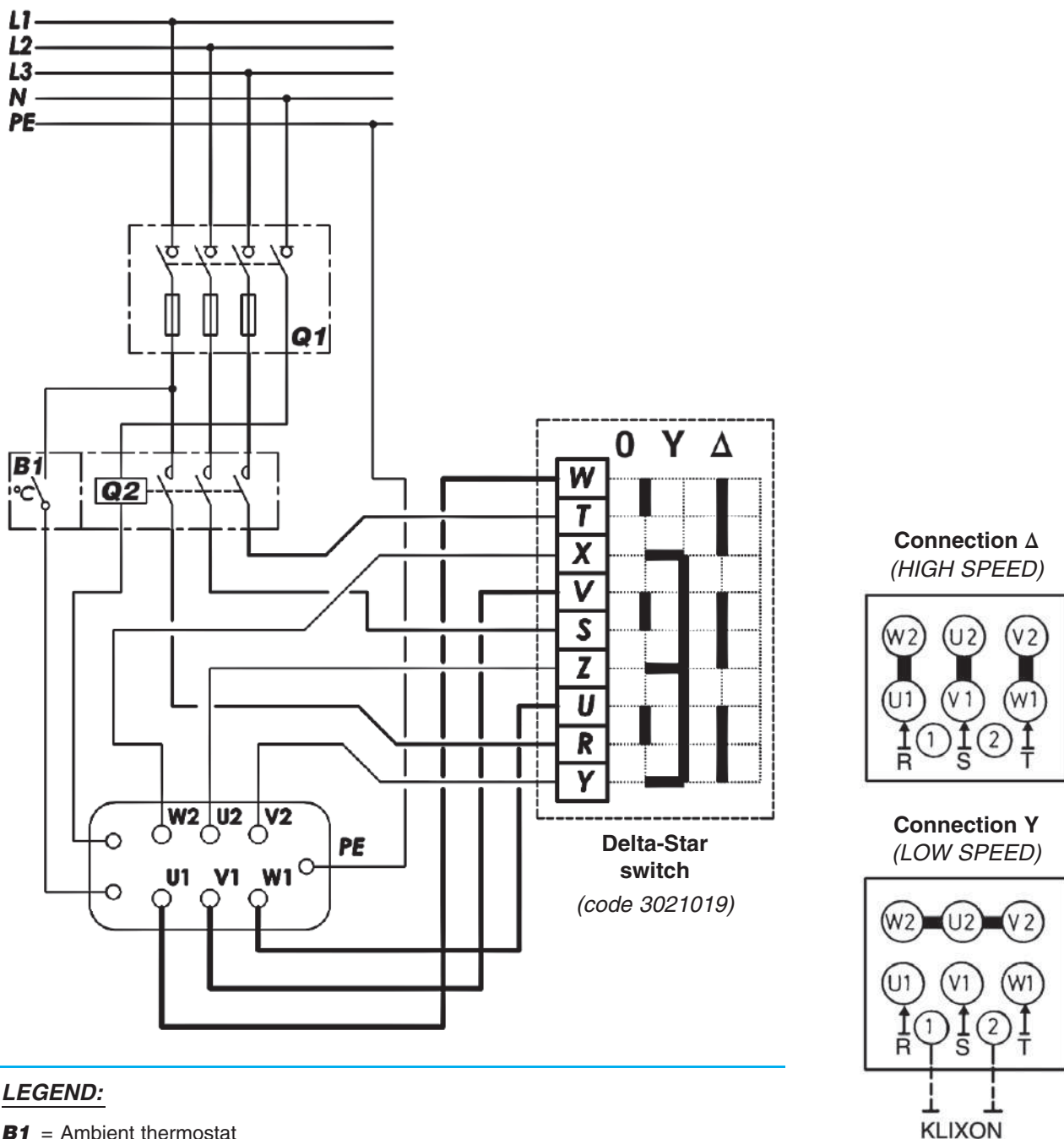

LEGEND:

B1 = Ambient thermostat

Q1 = Four poles circuit breakers with three poles protected by fuses

Q2 = Motor insertion power switch

Atlas / Helios version

POLES	SIZE	MOTOR CODE	SPEED (r.p.m.)		POWER (W)		ABSORPTION (A)	
			Δ	Y	Δ	Y	Δ	Y
4/6	1	3055030	1350	1000	130	85	0,28	0,15
	2	3055031	1350	1000	160	110	0,40	0,22
	3	3055032	1350	1000	280	190	0,75	0,40
	4	3055032	1350	1000	280	190	0,75	0,40
	5	3055033	1350	1000	530	360	1,06	0,65
	6	3055034	1350	1000	530	360	1,06	0,65
6/8	1	3054041	950	800	75	50	0,21	0,10
	2	3054041	950	800	75	50	0,21	0,10
	3	3054043	950	750	110	80	0,25	0,13
	4	3054043	950	750	110	80	0,25	0,13
	5	3054045	950	750	190	135	0,38	0,25
	6	3054046	950	750	200	150	0,48	0,25
	7	3054001	950	850	380	310	0,90	0,55
	8	3054000	940	770	670	490	1,55	1,00
	9	3054005	900	700	1030	710	2,50	1,50
	10	3054006	900	700	1520	1000	3,40	2,30

Janus 05 version

POLES	SIZE	MOTOR CODE	SPEED (r.p.m.)		POWER (W)		ABSORPTION (A)	
			Δ	Y	Δ	Y	Δ	Y
4/6	2	3055031	1350	1000	160	110	0,40	0,22
	4	3055032	1350	1000	280	190	0,75	0,40
6/8	6	3054046	950	750	200	150	0,48	0,25
	9	3054007	900	700	1030	710	2,50	1,50

AIX version

POLES	SIZE	MOTOR CODE	SPEED (r.p.m.)		POWER (W)		ABSORPTION (A)	
			Δ	Y	Δ	Y	Δ	Y
4/6	2	3055031	1350	1000	160	110	0,40	0,22
	4	3055032	1350	1000	280	190	0,75	0,40
	6	3055034	1350	1000	530	360	1,06	0,65
6/8	9	3054005	900	700	1030	710	2,50	1,50

Atlas STP version

POLES	SIZE	MOTOR CODE	SPEED (r.p.m.)		POWER (W)		ABSORPTION (A)	
			Δ	Y	Δ	Y	Δ	Y
6/8	7	3054000	940	770	670	490	1,55	1,00
	8	3054000	940	770	670	490	1,55	1,00
	9	3054006	900	750	1520	1000	3,40	2,30

Electric connection for more than one unit heater:

- With two speed Delta-Star motors, with Klixon thermic protection.
- Parallel connection for the unit heaters.
- Serial connection for the Klixon thermic protection.

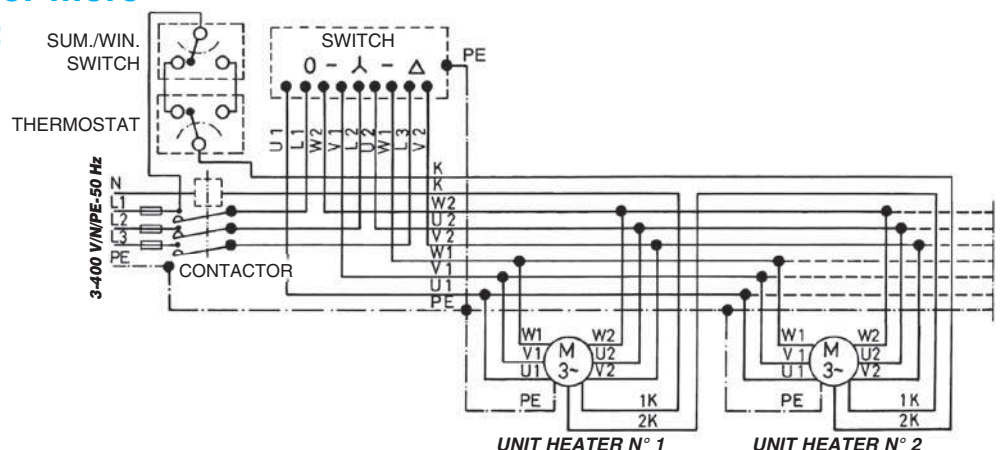

One speed motors, three phase, 230/400V 50Hz

Atlas / Helios unit heaters are supplied with a hermetically sealed 4 pole or 6 pole motor which is maintenance free. The motor is supplied as standard for a three phase 230/400V 50Hz supply. All motors are insulated to IP 44, class B protection.

Connection diagram

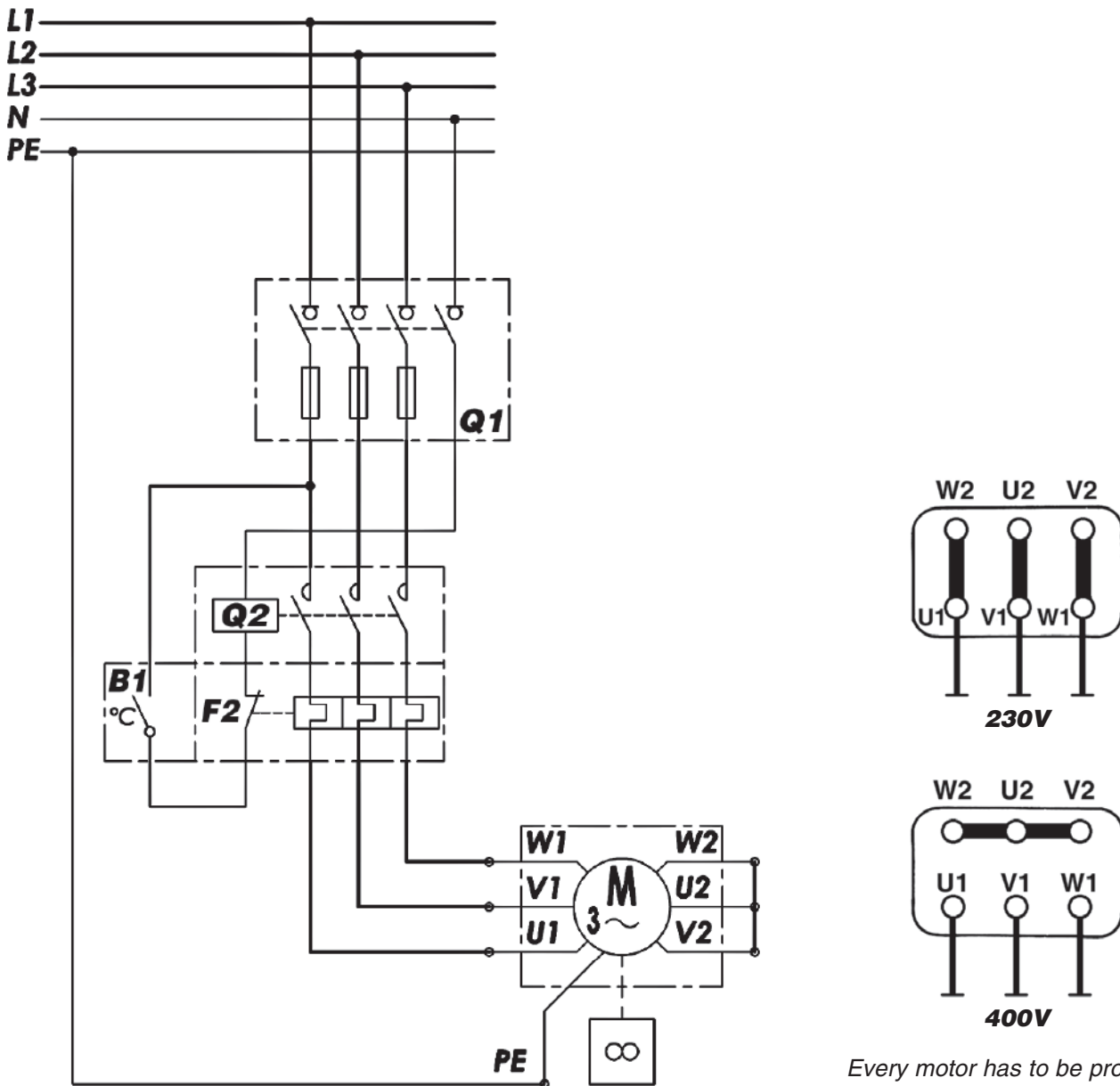

LEGEND:

- B1** = Ambient thermostat
- F2** = Thermic protection (thermal relay)
- Q1** = Four poles circuit breakers with three poles protected by fuses
- Q2** = Motor insertion power switch

Every motor has to be protected with a suitable protector calibrated at a current of 1,10 - 1,15 times the current indicated on the plate.

4 Pole Motor – 230/400V

SIZE	MOTOR CODE	SPEED (r.p.m.)	POWER (W)	ABSORPTION (A)	
				230V	400V
1	3050030	1400	180	0,68	0,39
2	3050030	1400	180	0,68	0,39
3	3050031	1400	290	1,21	0,70
4	3050031	1400	290	1,21	0,70
5	3050032	1400	530	1,90	1,10
6	3050033	1400	550	1,90	1,10

6 Pole Motor – 230/400V

SIZE	MOTOR CODE	SPEED (r.p.m.)	POWER (W)	ABSORPTION (A)	
				230V	400V
1	3051081	900	110	0,38	0,22
2	3051081	900	110	0,38	0,22
3	3051081	900	110	0,38	0,22
4	3051081	900	110	0,38	0,22
5	3051085	900	230	0,82	0,47
6	3051085	900	230	0,82	0,47

Single phase supply

One speed three phase 230 – 400V motors, IP 44 protection, supplied on unit heaters **Atlas/Helios** unit heaters can operate on single phase 230V 50Hz supply with the introduction of a suitable sized capacitor.

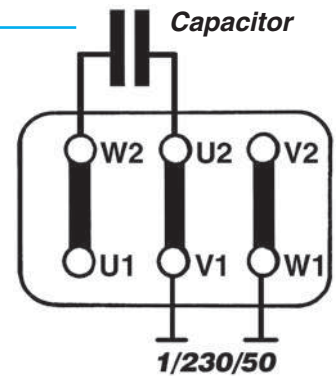

To reverse rotation connect **Capacitor** across “W2” and “V2”.

4 Pole Motor

SIZE	CAPACITOR CODE	CAPACITOR		ABSORPTION (A)
		CAPACITY (µF)	TENSION (VN)	
1	3021356	8,0	450	0,8
2	3021356	8,0	450	0,8
3	3021357	16,0	450	1,45
4	3021357	16,0	450	1,5
5	3021355	25,0	450	2,45
6	3021355	25,0	450	2,45

6 Pole Motor

SIZE	CAPACITOR CODE	CAPACITOR		ABSORPTION (A)
		CAPACITY (µF)	TENSION (VN)	
1	3021350	5,0	450	0,36
2	3021350	5,0	450	0,36
3	3021350	5,0	450	0,51
4	3021350	5,0	450	0,51
5	3021352	10,0	450	0,87
6	3021352	10,0	450	0,87

**Multi-function automatic control panel
for two speed Delta-Star motors, 4/6 or 6/8 poles, three phase, 400 V,
with Klixon thermic protection**

IDENTIFICATION	CODE
BSA-B	9007651
BSA-A	9007652
BSA-D	9007653

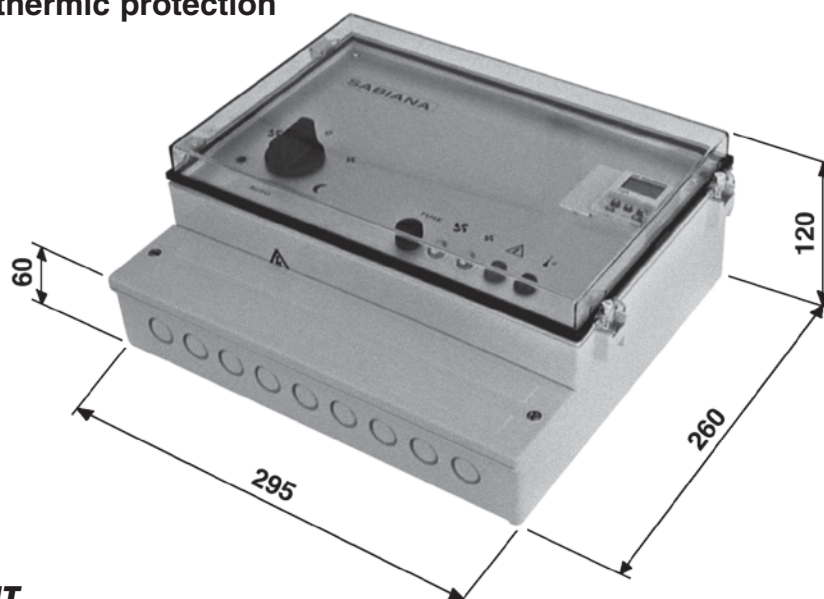

IMPORTANT

**THIS DEVICE IS NOT SUITABLE
FOR EX AMBIENT OR FOR THE CONTROL OF SINGLE-PHASE MOTORS.**

Description

Wall mounting plastic container complete with transparent door.

The front panel includes:

- control switch;
- timer / by-pass switch;
- signal lights;
- auxiliary protection fuse carrier;
- timer compartment cover (accessory).

Versions

- **BSA-B** without timer (Code 9007651)
- **BSA-A** with manual daily timer (Code 9007652)
- **BSA-D** with digital weekly timer (Code 9007653)

The basic version, BSA-B, is supplied without a timer, yet is ready to be fitted with this accessory if required.

Simply remove the timer cover, insert the timer chosen and connect it internally to the pre-installed wiring inside the control panel.

Technical specifications

- Wall control.
- Index of protection IP 40.
- Operating voltage 3 x 400V 50Hz.
- Control voltage 1 x 230V.
- Rated operating current 9 A 400V (AC3).

Application

Multi-position, multi-function switch for automatically controlling the speed of Sabiana unit heaters with two-speed, 400V three-phase motors.

Description

The control panel is supplied without a timer. The timer can be fitted after installation, by inserting it in the panel and connecting it electrically using the special pre-wired connector. Electromechanical daily timers and digital weekly timers are available.

Operation

- Control switch on “0”: disconnects power to the unit heaters and thus the unit heaters are off.
- Control switch on “fan”: continuous operation of the unit heater at low speed.
- Control switch on “FAN”: continuous operation of the unit heater at high speed.
- Control switch on “AUTO” (only for devices with timer, BSA-A and BSA-D): enables the automatic switching of the unit heater speed according to the status of an external 1- or 2-step thermostat. The timer can be combined with two different thermostats, with separate settings for night-time or daytime operation. **Using thermostats with changeover contacts allows automatic switching from low - high fan speed with the “day” thermostat, and low speed - fan off with the “night” thermostat.** Using two-step thermostats allows the speed of the unit heater to be switched automatically from high to low and to off when reaching the set temperature.
- Function switch on “day”: by-passes the timer and forces the connection to the “day” thermostat.
- Function switch on “night”: by-passes the timer and forces the connection to the “night” thermostat.

Anti-freeze function

The control is fitted for connection to an external room thermostat that is suitably set to a minimum required value. When the thermostat with anti-freeze function is connected, the control panel switches on the unit heater at low speed, even if the Control switch is on OFF.

Motor thermal overload devices

The Sabiana unit heater motors are fitted with internal TK thermal overload devices. The thermal overload device must be connected to the control panel, so that the latter automatically cuts off power to the unit heater if the overload is activated. If the control panel is connected to a series of unit heaters, the TK overload devices on each motor must be connected together in series, and then connected to the corresponding terminals on the control panel.

Electric connection

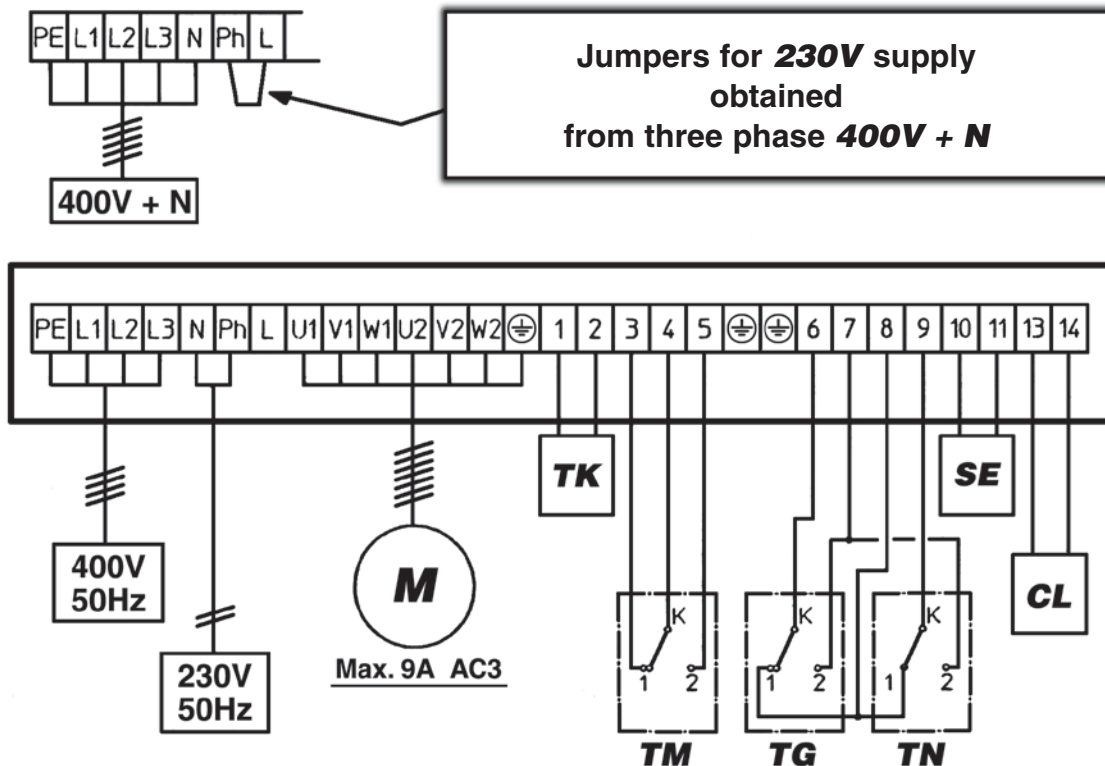

LEGEND:

- M** = Motor **TK** = Safety thermostat **TM** = Anti-frost thermostat **TG** = Day thermostat
TN = Night thermostat **SE** = Possible external switch **CL** = Extra connections

**Manual two-position switch
for two speed Delta-Star motors, 4/6 or 6/8 poles, three phase, 400 V,
with Klixon thermic protection**

IDENTIFICATION	CODE
BS 2S	9007654

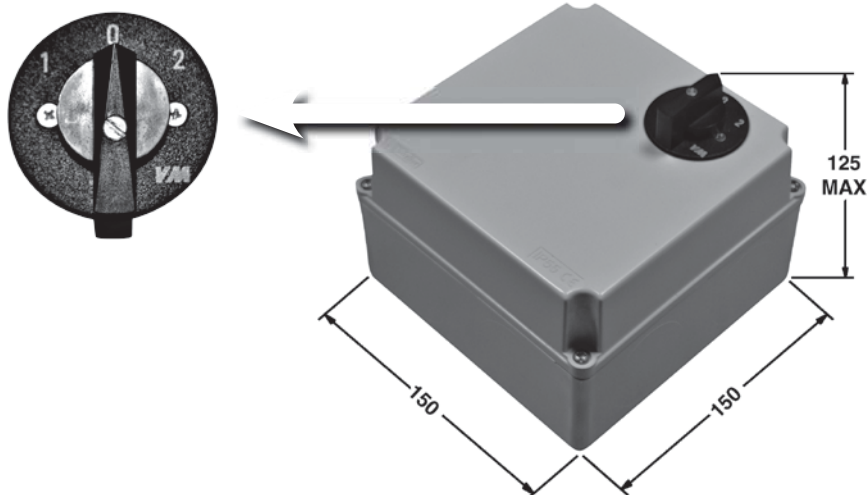

IMPORTANT

**THIS DEVICE IS NOT SUITABLE
FOR EX AMBIENT OR FOR THE CONTROL OF SINGLE-PHASE MOTORS.**

Description

Wall mounted plastic case, containing:

- 1 manual switch (1-0-2) for manually selecting the unit heater fan speed;
- 1 four pole control contactor;
- 1 voltage-free auxiliary contact used to control or lockout of external appliances.
- Terminal block for the connection of the unit heaters, motor overload devices and external thermostat.

Technical specifications

- Wall control.
- Index of protection IP 40.
- Operating voltage 3 x 400V 50Hz.
- Control voltage 1 x 230V.
- Rated operating current 9A 400V (AC3).

Applications

Switch for controlling the fan speed on one or more Sabiana unit heaters. The control can be connected to an external room thermostat.

Motor thermal overload devices

The Sabiana unit heater motors are fitted with internal TK thermal overload devices. The thermal overload device must be connected to the control panel, so that the latter automatically cuts off power to the unit heater if the overload is activated. If the control panel is connected to a series of unit heaters, the TK overload devices on each motor must be connected together in series, and then connected to the corresponding terminals on the control panel.

Electric connection

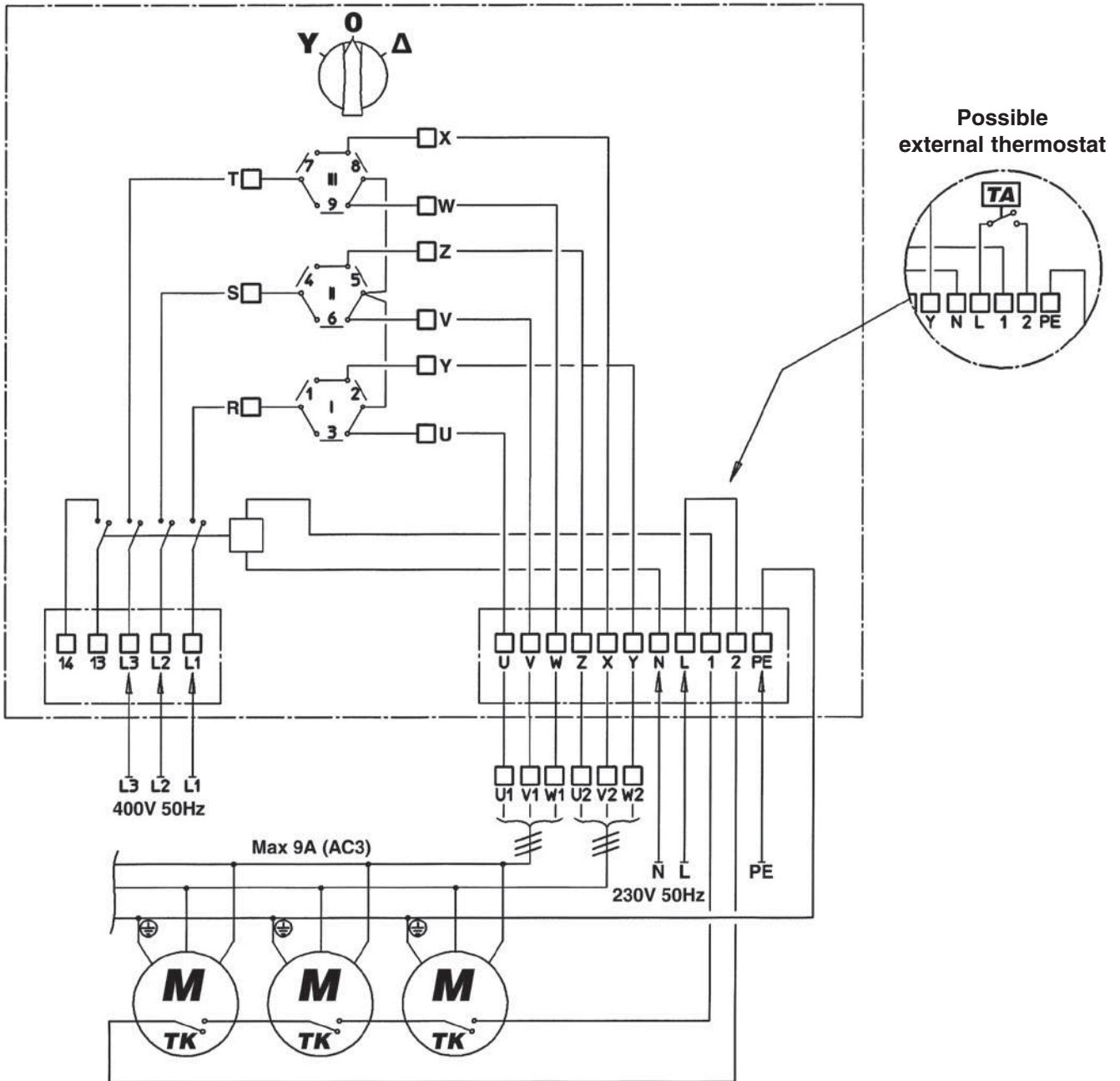

LEGEND:

Y = Low speed **Δ** = High speed **M** = Motor
TA = Room thermostat **TK** = Safety thermostat (Klixon)

**Manual two-position switch with thermostat
for two speed Delta-Star motors, 4/6 or 6/8 poles, three phase, 400 V,
with Klixon thermic protection**

IDENTIFICATION	CODE
BS 2-ST	9007655

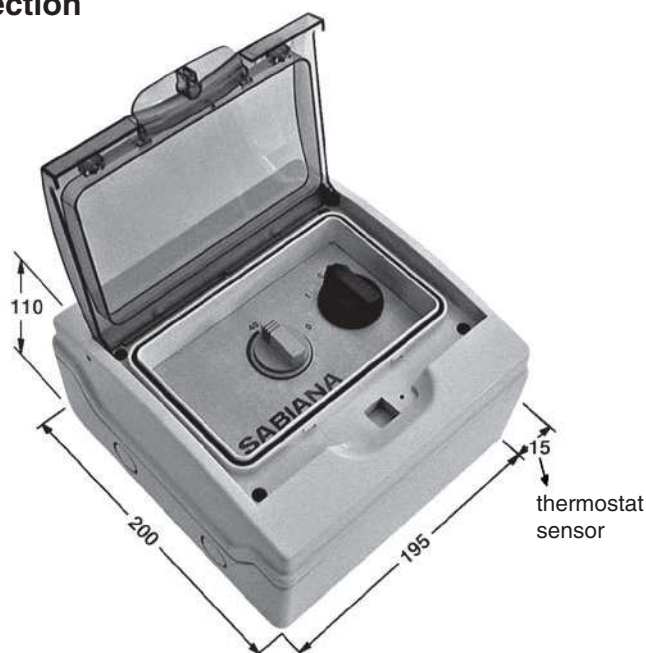
**IMPORTANT**

**THIS DEVICE IS NOT SUITABLE
FOR EX AMBIENT OR FOR THE CONTROL OF SINGLE-PHASE MOTORS.**

Description

Wall mounted plastic case, containing:

- 1 manual switch (1-0-2) for manually selecting the unit heater fan speed;
- 1 four pole control contactor;
- 1 voltage-free auxiliary contact used to control or lockout of external appliances;
- 1 room thermostat;
- Terminal block for the connection of the unit heaters, motor overload devices and external thermostat.

Technical specifications

- Wall control.
- Index of protection IP 40.
- Operating voltage 3 x 400V 50Hz.
- Control voltage 1 x 230V.
- Rated operating current 9A 400V (AC3).

Applications

Switch for controlling the fan speed on one or more Sabiana unit heaters, with built-in temperature control. Depending on the set room temperature, the control stops or starts the unit heaters at the speed selected on the speed switch. The bulb of the thermostat is positioned outside of the panel casing.

Motor thermal overload devices

The Sabiana unit heater motors are fitted with internal TK thermal overload devices. The thermal overload device must be connected to the control panel, so that the latter automatically cuts off power to the unit heater if the overload is activated. If the control panel is connected to a series of unit heaters, the TK overload devices on each motor must be connected together in series, and then connected to the corresponding terminals on the control panel.

Installation

Check that the position chosen for the installation of the panel does not affect the correct operation of the room thermostat. Avoid fastening the control panel to cold walls, in areas affected by cold/hot air currents or at an unusual height.

Electric connection

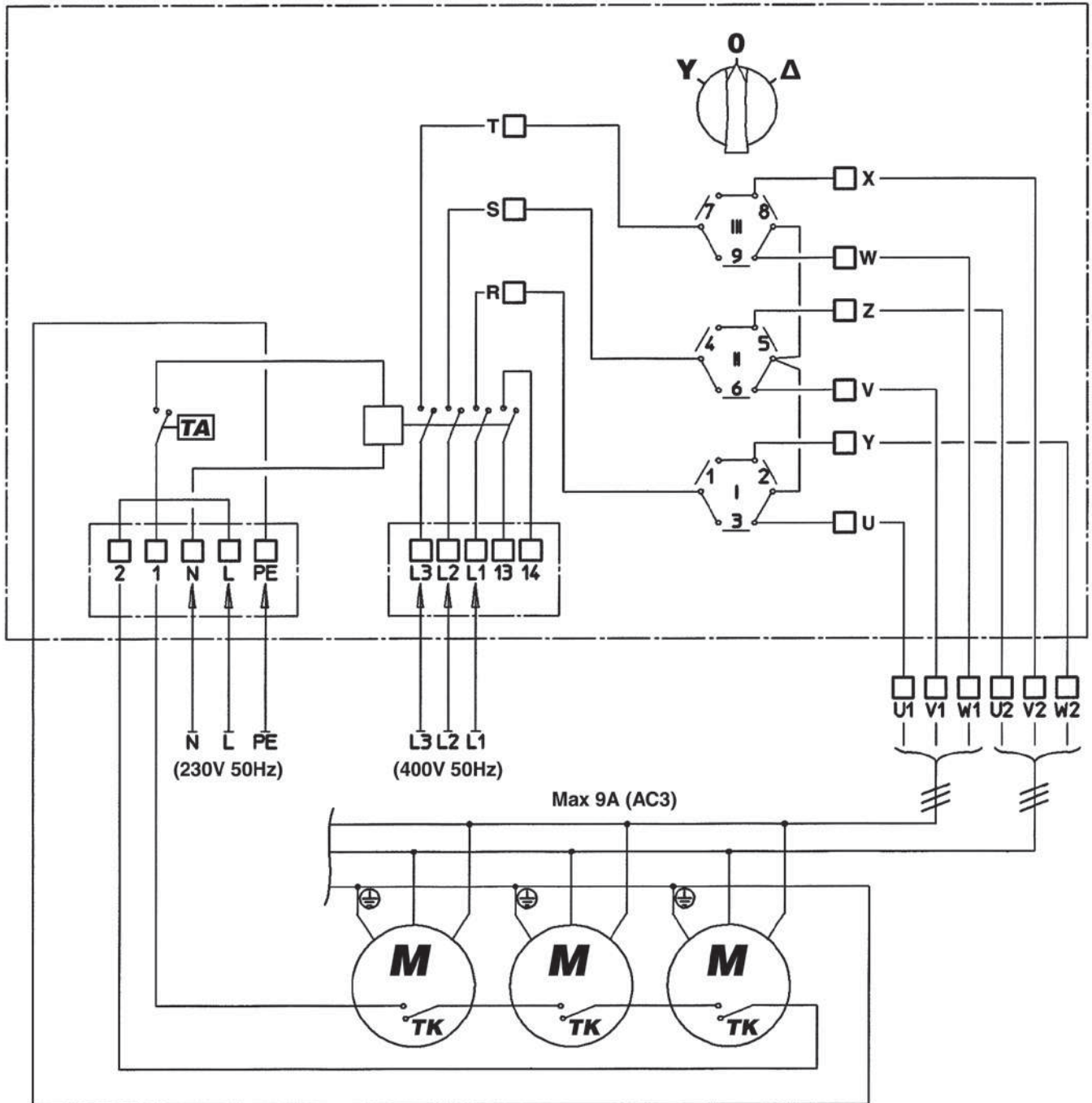

LEGEND:

- Y** = Low speed **Δ** = High speed **M** = Motor
TA = Room thermostat **TK** = Safety thermostat (Klixon)

**Manual three-position switch with thermostat
for two speed Delta-Star motors, 4/6 or 6/8 poles, three phase, 400 V,
with Klixon thermic protection**

IDENTIFICATION	CODE
BS 3-ST	9007656

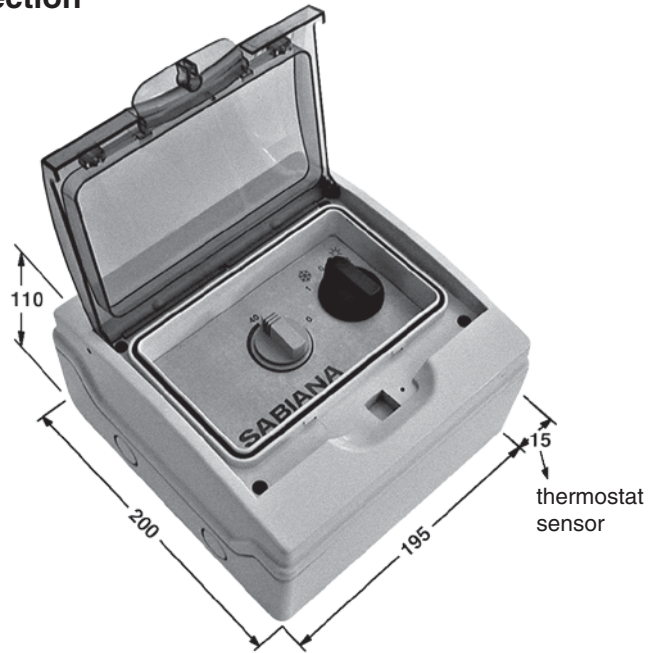

IMPORTANT

**THIS DEVICE IS NOT SUITABLE
FOR EX AMBIENT OR FOR THE CONTROL OF SINGLE-PHASE MOTORS.**

Description

Wall mounted plastic case, containing:

- 1 manual switch for manually selecting the unit heater fan speed as follows:
in Summer 1 speed selection, low speed only (0-1) – in Winter 2 speed selections (0-1-2);
- 1 four pole control contactor;
- 1 voltage-free auxiliary contact used to control or lockout of external appliances;
- 1 room thermostat;
- Terminal block for the connection of the unit heaters, motor overload devices and external thermostat.

Technical specifications

- Wall control.
- Index of protection IP 40.
- Operating voltage 3 x 400V 50Hz.
- Control voltage 1 x 230V.
- Rated operating current 9A 400V (AC3).

Applications

Switch for controlling the fan speed on one or more Sabiana unit heaters, with built-in temperature control. Depending on the set room temperature, the control stops or starts the unit heaters at the speed selected on the speed switch. The bulb of the thermostat is positioned outside of the panel casing.

Motor thermal overload devices

The Sabiana unit heater motors are fitted with internal TK thermal overload devices. The thermal overload device must be connected to the control panel, so that the latter automatically cuts off power to the unit heater if the overload is activated. If the control panel is connected to a series of unit heaters, the TK overload devices on each motor must be connected together in series, and then connected to the corresponding terminals on the control panel.

Installation

Check that the position chosen for the installation of the panel does not affect the correct operation of the room thermostat. Avoid fastening the control panel to cold walls, in areas affected by cold/hot air currents or at an unusual height.

Electric connection

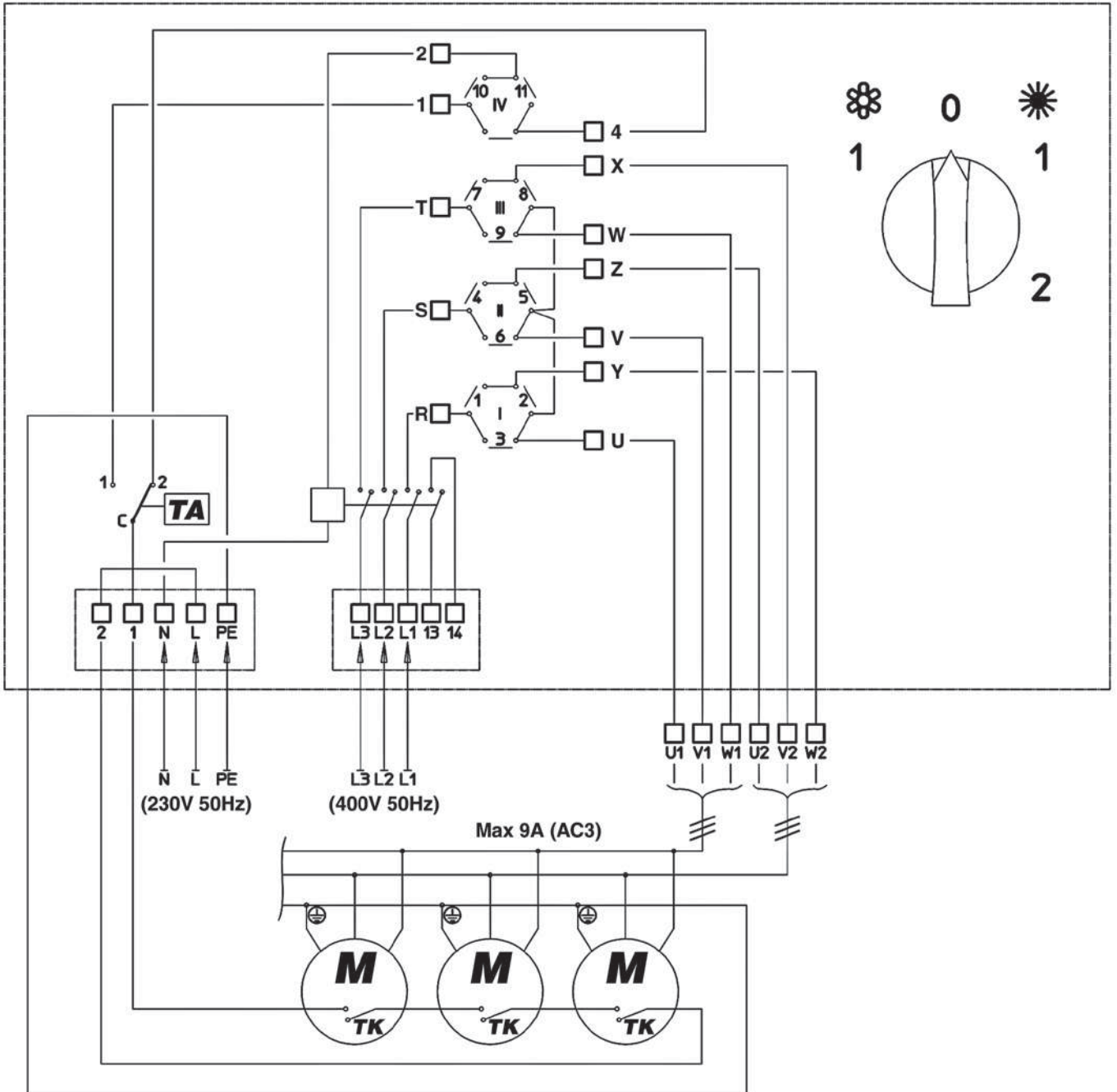

LEGEND:

- Y** = Low speed **Δ** = High speed **M** = Motor
TA = Room thermostat **TK** = Safety thermostat (Klixon)

Hot water or high temperature hot water connections

Horizontal discharge

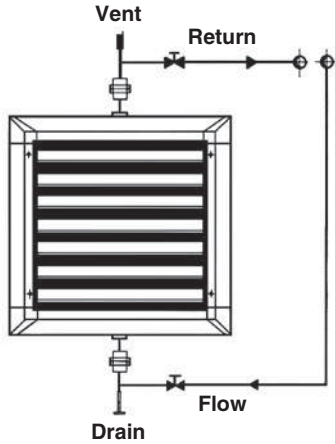

Downflow discharge

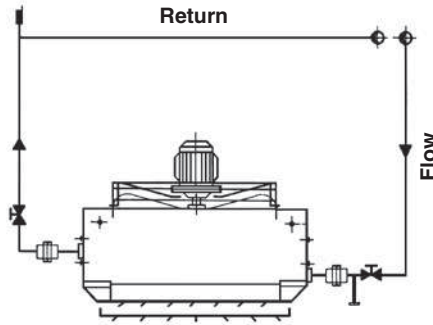

Steam connections

Horizontal discharge

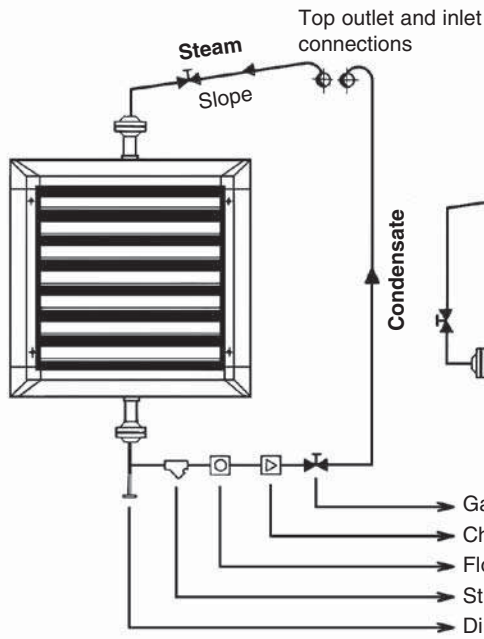

Downflow discharge

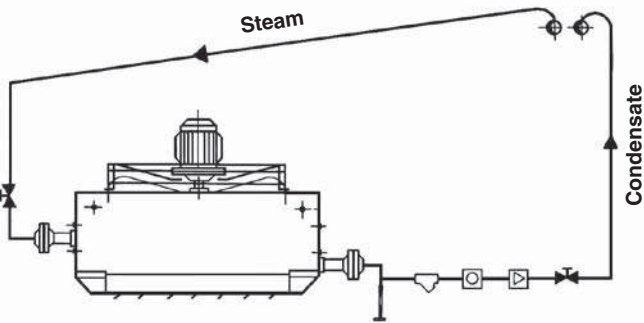

*FOR STEAM
WE RECOMMEND THE USE
OF COPPER TUBE COILS.*

Janus 05 version – Hydraulic connections

Installation details
for hydraulic connections

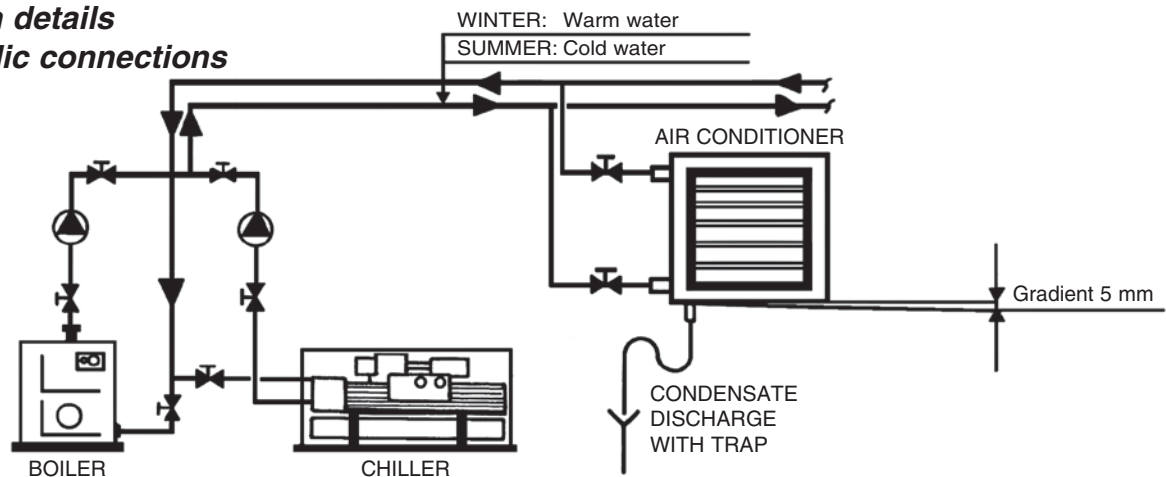



ICIM

www.icim.it

CISQ is a member of



www.iqnet-certification.com

IQNet, the association of the world's first class certification bodies, is the largest provider of management System Certification in the world. IQNet is composed of more than 30 bodies and counts over 150 subsidiaries all over the globe.

CERTIFICATO n. **0545/6**
CERTIFICATE No. _____

SI CERTIFICA CHE IL SISTEMA DI GESTIONE PER LA QUALITA' DI
WE HEREBY CERTIFY THAT THE QUALITY MANAGEMENT SYSTEM OPERATED BY

SABIANA S.p.A.

Sede e Unità Operativa
Via Piave, 53 - 20011 Corbetta (MI)
Direzione e uffici amministrativi, progettazione, assistenza, produzione di apparecchiature per il riscaldamento e il condizionamento dell'aria (aerotermi, termostrisce radianti, unità trattamento aria) e canne fumarie
Unità Operativa
Via Virgilio, 2 - 20013 Magenta (MI)
Produzione di ventilconvettori, magazzino e logistica
Italia

E' CONFORME ALLA NORMA
IS IN COMPLIANCE WITH THE STANDARD

UNI EN ISO 9001:2008

PER LE SEGUENTI ATTIVITA'
FOR THE FOLLOWING ACTIVITIES

EA: 18

Progettazione, produzione e assistenza di apparecchiature per il riscaldamento e il condizionamento dell'aria (aerotermi, termostrisce radianti, ventilconvettori e unità trattamento aria) e canne fumarie.
Design, production and service of heating and air conditioning equipment (unit heaters, radiant panels, fan coil units and air handling units) and chimneys.

Riferirsi al Manuale della Qualità per l'applicabilità dei requisiti della norma di riferimento.
Refer to Quality Manual for details of application to reference standard requirements.

Il presente certificato è soggetto al rispetto del regolamento per la certificazione dei sistemi di gestione per la qualità delle aziende.
The use and the validity of this certificate shall satisfy the requirements of the rules for the certification of company quality management systems.

Data emissione
First issue
10/06/1996

Emissione corrente
Current issue
10/04/2015

Data di scadenza
Expiring date
09/04/2018

ICIM S.p.A.

Piazza Don Enrico Mapelli, 75 - 20099 Sesto San Giovanni (MI)



SGQ N° 004 A SSI N° 008 G
SGA N° 005 D PRD N° 004 B
SCR N° 006 F ISP N° 046 E
PRS N° 002 C SGE N° 005 M

Membro degli Accordi di Mutuo Riconoscimento EA, IAF e ILAC
Signatory of EA, IAF and ILAC Mutual Recognition Agreements

CISQ è la Federazione Italiana di Organismi di Certificazione dei sistemi di gestione aziendale.

CISQ is the Italian Federation of management system Certification Bodies.



www.cisq.com

The descriptions and illustrations provided in this publication are not binding: Sabiana reserves the right, whilst maintaining the essential characteristics of the types described and illustrated, to make, at any time, without the requirement to promptly update this piece of literature, any changes that it considers useful for the purpose of improvement or for any other manufacturing or commercial requirements.

Heating / Air Conditioning
Atlas and Helios Unit Heaters
Janus 05 Air Conditioners
AIX Stainless Steel Unit Heaters
Atlas STP Door Curtains
Jetstream Induction Flow Optimizers



SABIANA
IL CLIMA AMICO

A leading brand of  **AFG**

Sabiana s.p.a. • via Piave, 53 • 20011 Corbetta • Milano • Italy • phone +39.02.97203.1 r.a. / +39.02.97270429 / +39.02.97270576
fax +39.02.9777282 / +39.02.9772820 • www.sabiana.it • info@sabiana.it

AH - EX - 05 /15
Cod. A4070100 D/05/15